



Warning: To reduce the risk of injury, read the pressure washer instruction manual and the engine instruction manual before operating pressure washer.



STOP IF YOU EXPERIENCE ANY ISSUES WITH YOUR PRESSURE WASHER, WE ARE HERE TO HELP YOU.

Call 1-877-362-4271

SHOULD YOU REQUIRE ASSISTANCE WITH A PART THAT MAY BE BROKEN OR MISSING YOU ARE HAVING DIFFICULTY WITH ASSEMBLY OR STARTING PLEASE CONTACT US. YOUR COMPLETE SATISFACTION IS OUR PRIMARY OBJECTIVE

NOTICE: Use of fuels with greater than 10% ethanol are not approved for use in this product per EPA regulations and will damage the unit and void the warranty

Ethanol Percentage
 <10% OK NO 15%–30%–85%

QUICK SETUP GUIDE

(Letters A-C)

A Install the handle
Place handle onto frame, depress the snap buttons, and slide the handle assembly onto the frame until snap buttons snap into place.

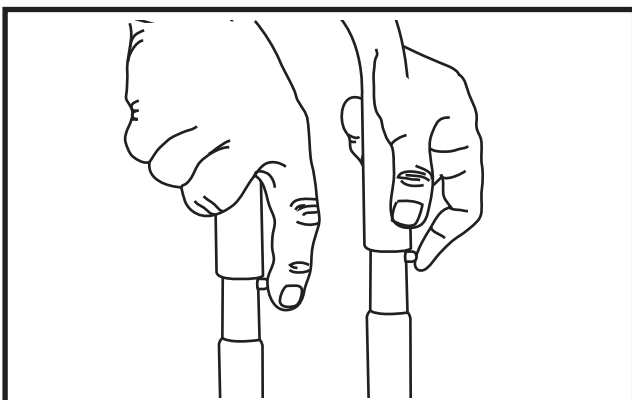

B Add/ Check Oil
The engine is shipped without oil. Before starting engine, add the oil provided. Check oil level prior to each use. Refer to Engine Owner's Manual for complete procedure.

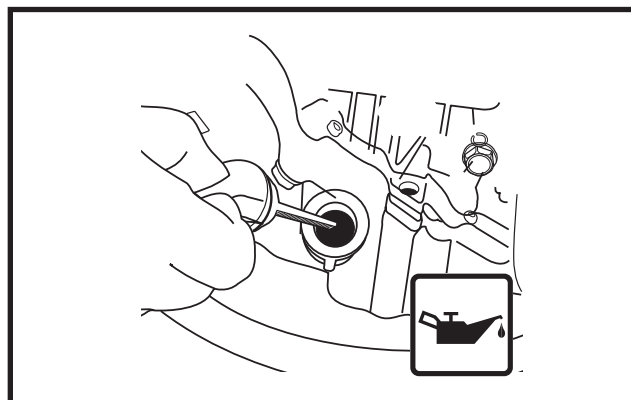

C Add Gasoline
In a well ventilated outdoor area add fresh, high quality, unleaded gasoline with a pump octane rating of 86 or higher. Do not overfill. Wipe up spilled fuel before starting the engine. Refer to Engine Owner's Manual for complete procedure

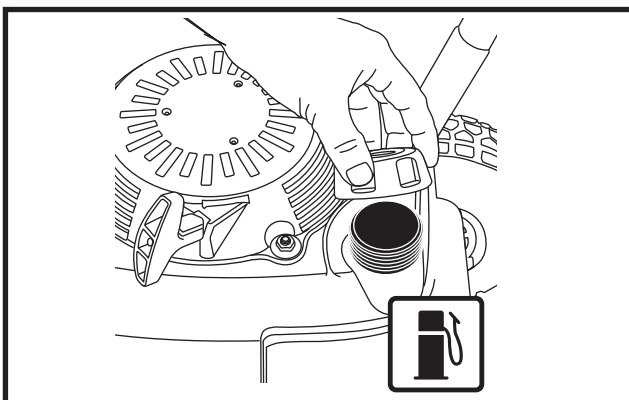

Important: Ethanol Shield™ (sold separately) is a fuel stabilizer that helps eliminate and prevent ethanol related problems in power equipment. Follow the instructions on the container and add to the gasoline

Danger:



- Never run engine indoors, or in enclosed, poorly ventilated areas. Engine exhaust contains carbon monoxide, an odorless and deadly gas.
- Risk of fluid injection and laceration. When using the high-pressure setting, DO NOT allow the high-pressure spray to come in contact with unprotected skin, eyes or with any pets or animals. serious injury will occur.

QUICK START GUIDE

(Numbers 1-11)

1 Connect Garden Hose to Pump
Thread the garden hose to the pump inlet.

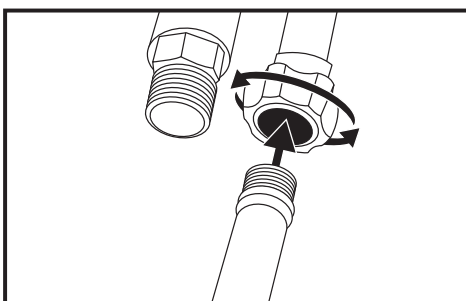

2 Connect High Pressure Hose to Pump
Thread the high pressure hose to the pump outlet.

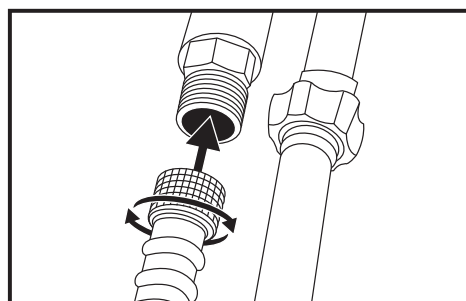

3 Connect High Pressure Hose to Spray Gun
Thread the other end of the high pressure hose to the spray gun.

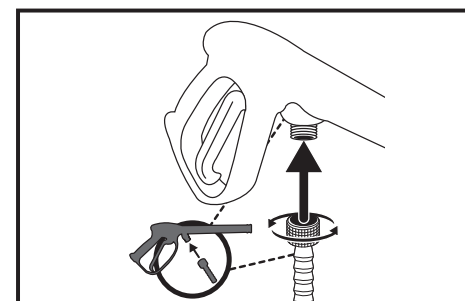

4 Connect Spray Wand to Spray Gun
Thread the spray wand into the end of the spray gun.

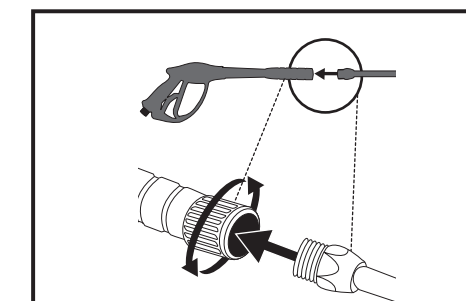

5 Connect QC Nozzles to Spray Wands
Pull quick connect coupler back and insert nozzle. Release quick connect coupler and twist nozzle to make sure it is secure in coupler.

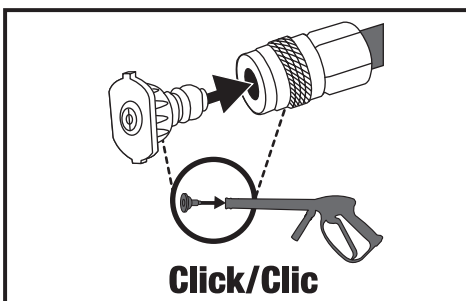

6 Turn Water Faucet Completely On
Do not run the unit without water supply connected and turned on. Use Cold Water Only.

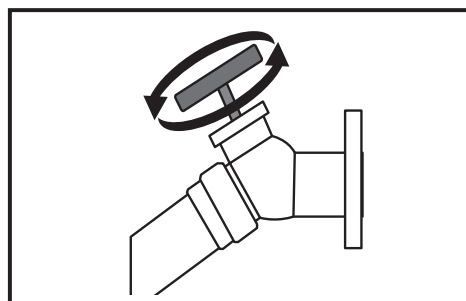

7 Release Air from System
Release all air from the pump and high pressure hose by depressing trigger until a steady stream of water is present. Approximately 30 seconds.

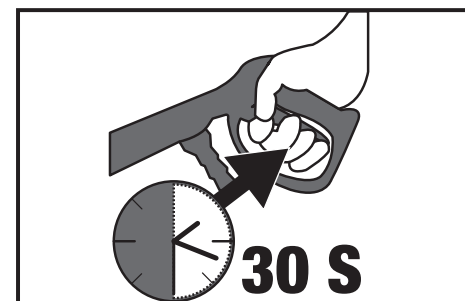

8 Verify the Engine Switch is turned ON Position

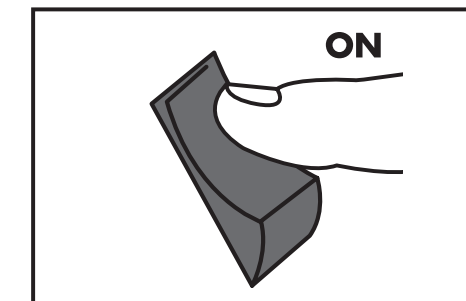

9 Move the Choke to the CHOKE position

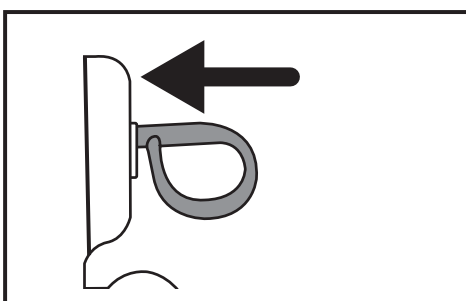

10 Pull the Recoil Starter Grip
Pull the recoil starter grip to start the engine

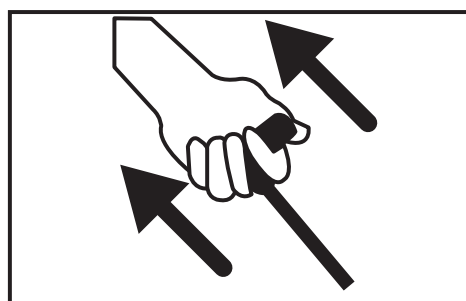

11 Move the Choke to the RUN Position
Gradually move the Choke to the RUN position after engine starts.

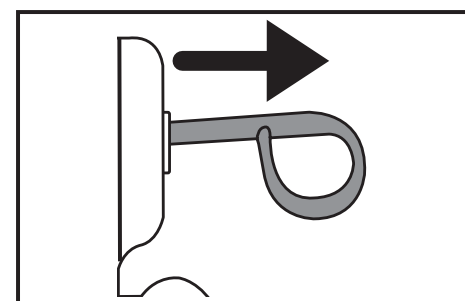

Important: This Guide is not a substitute for reading the instruction manual. Use must read and understand operator's manual before using this product.



ADVERTENCIA: Para reducir el riesgo de heridas, lea el manual de instrucciones de la lavadora a presión y el manual de instrucciones del motor antes de usar la lavadora a presión.



SI TIENE CUALQUIER PROBLEMA CON SU LAVADORA A PRESIÓN, ESTAMOS AQUÍ PARA AYUDARLE.

o llame al 1-877-362-4271

SI NECESITA AYUDA CON ALGUNA PIEZA QUE PUDIERA ESTAR ROTA O FALTANTE, O SI TIENE PROBLEMAS PARA ARMAR O HACER FUNCIONAR EL PRODUCTO, LLÁMENOS A NOSOTROS. NUESTRO PRINCIPAL OBJETIVO ES SU COMPLETA SATISFACCIÓN.

Porcentaje de etanol
 <10% OK NO 15%–30%–85%

AVISO: Utilice a combustibles que contengan más de 10% de etanol no están aprobado para su uso en este producto por reglamentos de la EPA y puede dañar la unidad y anular la garantía

GUÍA DE CONFIGURACIÓN RÁPIDA

(Letters A-C)

A Instale la manija
Coloque la manija sobre el bastidor, presione los botones de traba y deslice la manija sobre el bastidor hasta que los botones de traba se traben en su lugar.

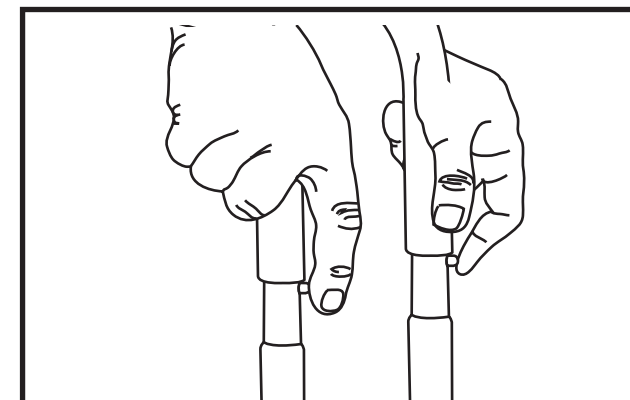

B Agregue/revise el aceite
El motor viene sin aceite. Antes de hacer funcionar el motor, agregue el aceite suministrado usando el pico para el aceite. Revise el aceite antes de cada uso. Consulte el manual del usuario del motor por el procedimiento completo.

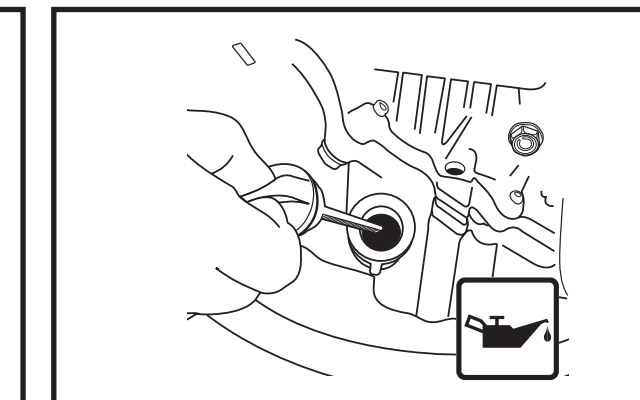

C Agregue gasolina
En un área bien ventilada y al exterior, agregue gasolina fresca, de alta calidad y sin plomo con un índice de octanaje de 86 o mayor. No lo llene de más. Limpie todo el combustible derramado antes de encender el motor. Consulte el manual del usuario del motor por el procedimiento completo.

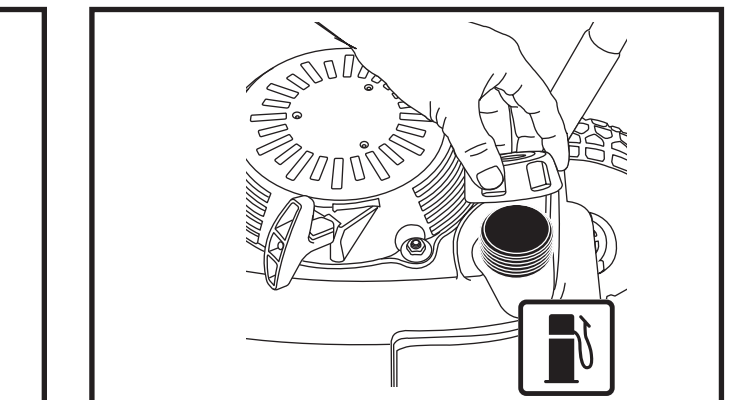

IMPORTANTE: Ethanol Shield™ (se vende por separado) es un estabilizador de combustible que ayuda a eliminar y prevenir los problemas relacionados con el etanol en equipos de potencia. Siga las instrucciones en el envase y añadir a la gasolina.



Peligro:

- Nunca haga funcionar el motor en el interior o en áreas cerradas o poco ventiladas. las emisiones del motor contienen monóxido de carbono, un gas olor y letal.
- Riesgo de inyección de fluido y de cortes. Al usar el modo de alta presión, NO permita que el rocío de alta presión entre en contacto con la piel desprotegida, los ojos o con mascotas o animales. Causará heridas graves.

GUÍA DE INICIO RÁPIDO

(Números 1-11)

1 Conecte la manguera de jardín a la bomba
Enrosque la manguera de jardín a la entrada de la bomba.

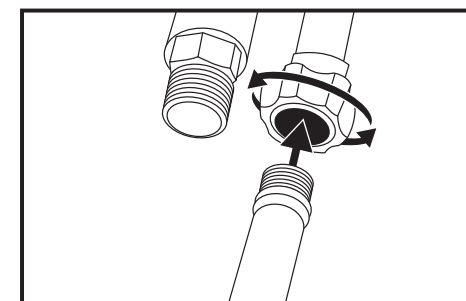

2 Conecte la manguera de alta presión a la bomba
Conecte la manguera de alta presión a la salida de la bomba.

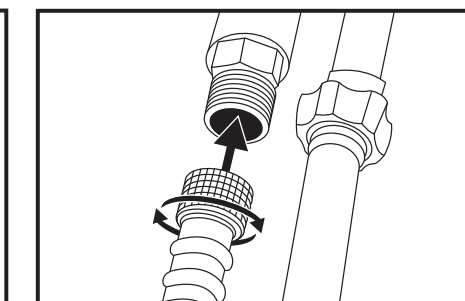

3 Conecte la manguera de alta presión a la pistola rociadora
Enrosque el otro extremo de la manguera de alta presión a la pistola rociadora

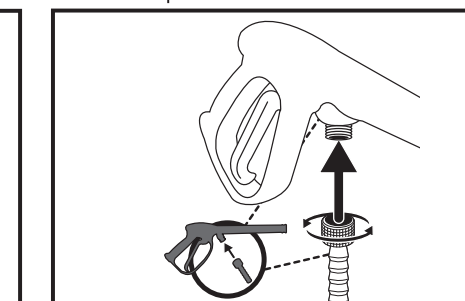

4 Conecte la vara rociadora a la pistola rociadora
Enrosque la vara rociadora al extremo de la pistola rociadora.

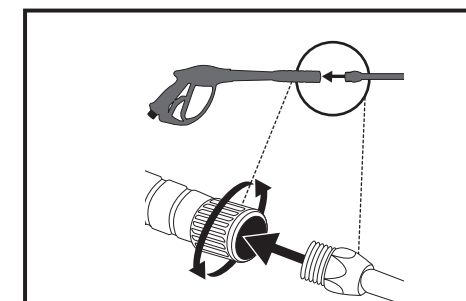

5 Conecte las boquillas QC a la vara rociadora
Enrosque la vara rociadora al extremo de la pistola rociadora.

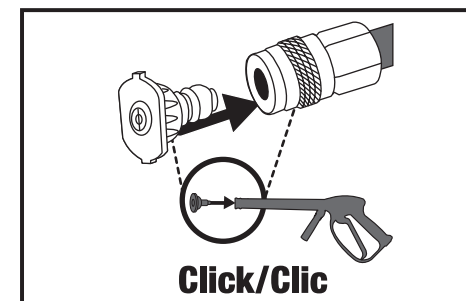

6 Abra completamente la llave del agua
No haga funcionar la unidad sin el suministro de agua conectado y abierto. Use agua fría solamente.

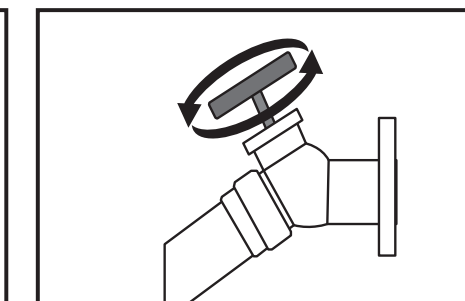

7 Libere el aire del siste
Libere el aire de la bomba y de la manguera de alta presión presionando el gatillo hasta que salga un flujo continuo de agua. Aproximadamente 30 segundos.

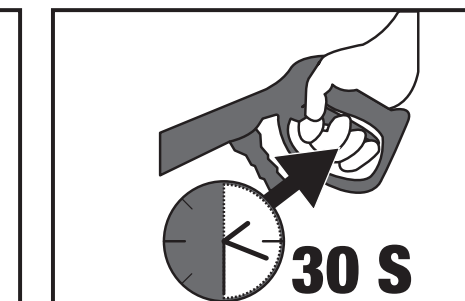

8 Verifique que el interruptor del motor esté en la posición ENCENDER

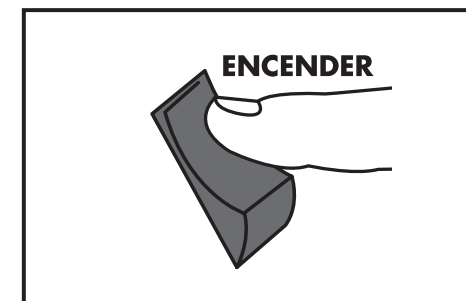

9 Mueva el cebador a la posición ANEGADOR

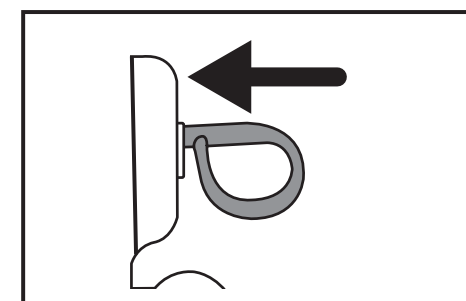

10 Tire del arranque manual
Tire del arranque manual para encender el motor.

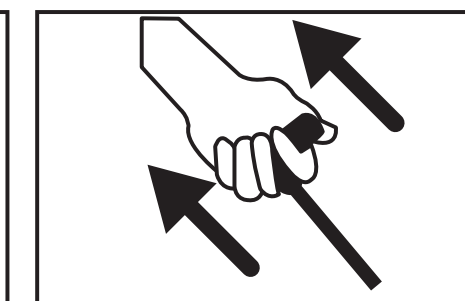

11 Mueva el cebador a la posición MARCHA
Mueva lentamente el cebador hacia la posición MARCHA después de que el motor haya arrancado.

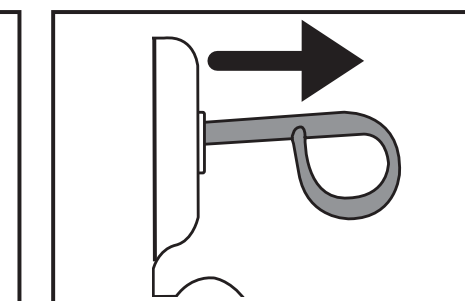

ADVERTENCIA: Comprender la Guia Rápido no equivale a leer el manual de instrucciones. El usuario debe leer y comprender el manual del operador antes de usar este producto

Warning: To reduce the risk of injury, read the pressure washer instruction manual and the engine instruction manual before operating pressure washer.

STOP IF YOU EXPERIENCE ANY ISSUES WITH YOUR PRESSURE WASHER, WE ARE HERE TO HELP YOU.

or call 1-877-362-4271

SHOULD YOU REQUIRE ASSISTANCE WITH A PART THAT MAY BE BROKEN OR MISSING YOU ARE HAVING DIFFICULTY WITH ASSEMBLY OR STARTING PLEASE CONTACT US. YOUR COMPLETE SATISFACTION IS OUR PRIMARY OBJECTIVE

NOTICE: Use of fuels with greater than 10% ethanol are not approved for use in this product per EPA regulations and will damage the unit and void the warranty

Ethanol Percentage
 <10% OK NO 15%–30%–85%

QUICK SETUP GUIDE

(Letters A-C)

A Install the handle
 Place handle onto frame, depress the snap buttons, and slide the handle assembly onto the frame until snap buttons snap into place.

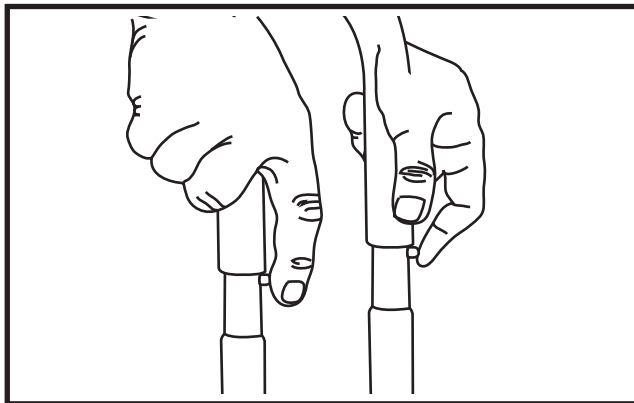

B Add/ Check Oil
 The engine is shipped without oil. Before starting engine, add the oil provided. Check oil level prior to each use. Refer to Engine Owner's Manual for complete procedure.

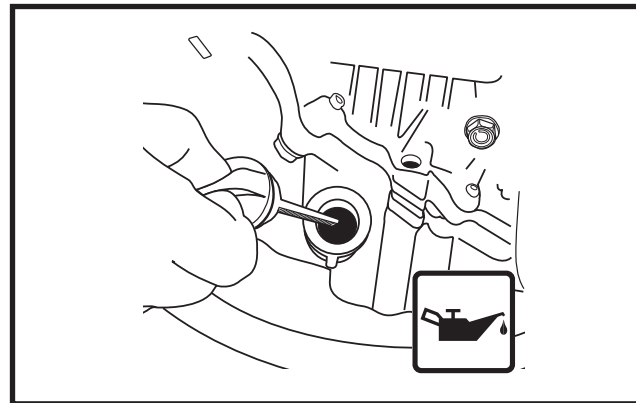

C Add Gasoline
 In a well ventilated outdoor area add fresh, high quality, unleaded gasoline with a pump octane rating of 86 or higher. Do not overfill. Wipe up spilled fuel before starting the engine. Refer to Engine Owner's Manual for complete procedure

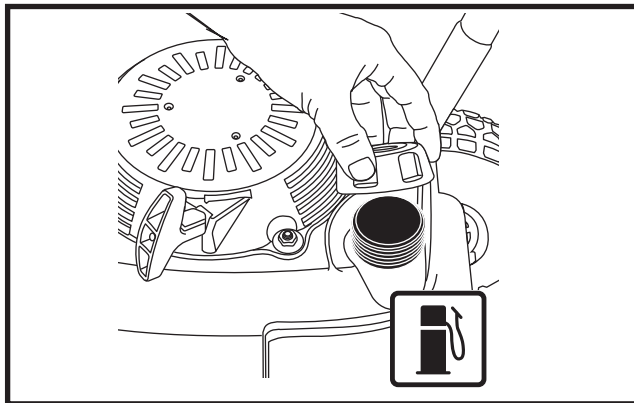

Important: Ethanol Shield™ (sold separately) is a fuel stabilizer that helps eliminate and prevent ethanol related problems in power equipment. Follow the instructions on the container and add to the gasoline

Danger:

- Never run engine indoors, or in enclosed, poorly ventilated areas. Engine exhaust contains carbon monoxide, an odorless and deadly gas.
- Risk of fluid injection and laceration. When using the high-pressure setting, DO NOT allow the high-pressure spray to come in contact with unprotected skin, eyes or with any pets or animals. serious injury will occur.

QUICK START GUIDE

(Numbers 1-11)

1 Connect Garden Hose to Pump
 Thread the garden hose to the pump inlet.

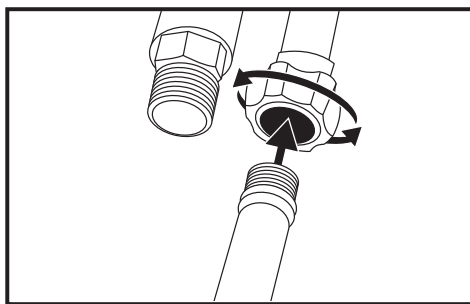

2 Connect High Pressure Hose to Pump
 Thread the high pressure hose to the pump outlet.

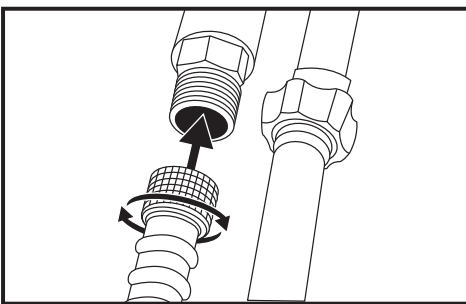

3 Connect High Pressure Hose to Spray Gun
 Thread the other end of the high pressure hose to the spray gun.

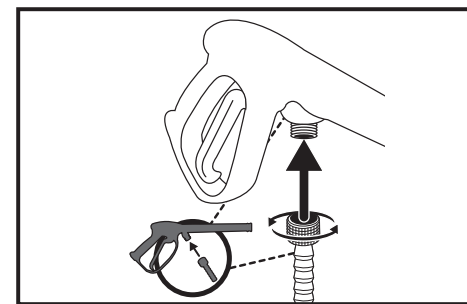

4 Connect Spray Wand to Spray Gun
 Thread the spray wand into the end of the spray gun.

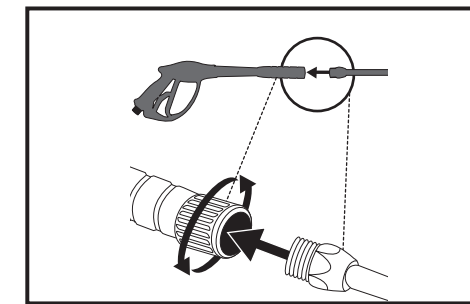

5 Connect QC Nozzles to Spray Wands
 Pull quick connect coupler back and insert nozzle. Release quick connect coupler and twist nozzle to make sure it is secure in coupler.

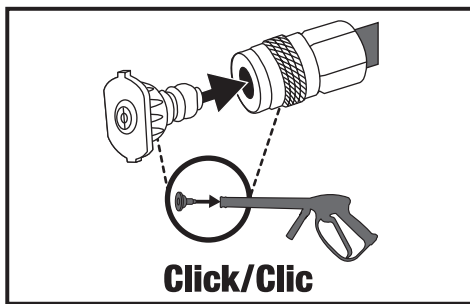

6 Turn Water Faucet Completely On
 Do not run the unit without water supply connected and turned on. Use Cold Water Only.

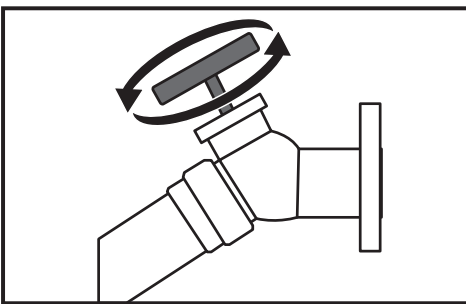

7 Release Air from System
 Release all air from the pump and high pressure hose by depressing trigger until a steady stream of water is present. Approximately 30 seconds.

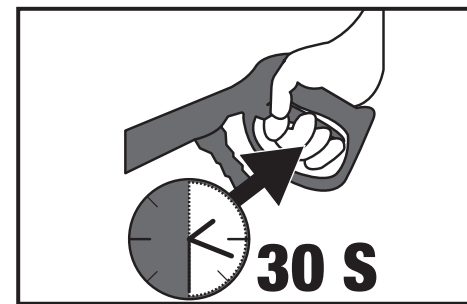

8 Verify the Engine Switch is turned ON Position

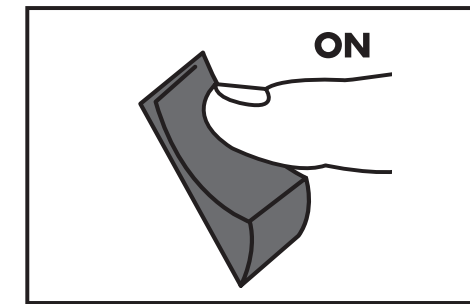

9 Move the Choke to the CHOKE position

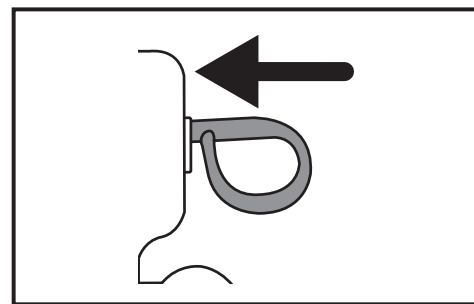

10 Pull the Recoil Starter Grip
 Pull the recoil starter grip to start the engine

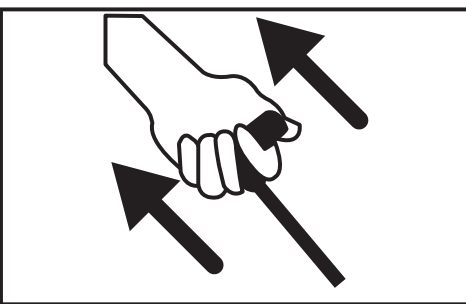

11 Move the Choke to the RUN Position
 Gradually move the Choke to the RUN position after engine starts.

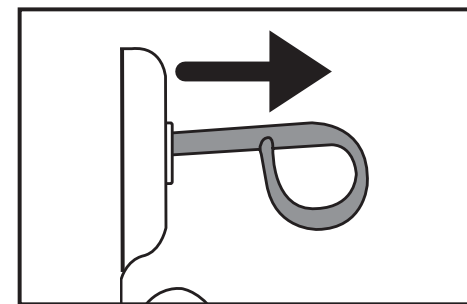

WARNING: This Guide is not a substitute for reading the instruction manual. User must read and understand operator's manual before using this product.

AVERTISSEMENT: Pour réduire le risque de blessure, veuillez lire le manuel d'instructions de la laveuse à pression et du moteur avant d'utiliser l'appareil.

STOP SI VOUS AVEZ DES PROBLÈMES AVEC VOTRE LAVEUSE À PRESSION, NOUS SOMMES ICI POUR VOUS AIDER.

ou appelez-nous au 1-877-362-4271

SI VOUS AVEZ BESOIN D' AIDE AVEC UNE PIÈCE QUI POURRAIT ÊTRE BRISÉE OU MANQUANTE OU SI VOUS AVEZ DE LA DIFFICULTÉ AVEC L' ASSEMBLAGE OU LA MISE EN MARCHÉ, VEUILLEZ NOUS CONTACTER. VOTRE ENTÈRE SATISFACTION EST NOTRE OBJECTIF PRINCIPAL

Pourcentage d'éthanol
 <10% OK NO 15%–30%–85%

AVIS : Utilisez de carburants dont la teneur en éthanol est supérieure à 10 % ne sont pas approuvés pour une utilisation dans ce produit par la réglementation de l'EPA et risque d'endommager l'appareil et annuler la garantie

GUIDE D'INSTALLATION RAPIDE

(Letters A-C)

A Installation de la poignée
 Placez l'ensemble de poignée sur le cadre, enfoncez les boutons-poussoirs et glissez l'ensemble de poignée dans le cadre jusqu'à ce que les boutons-poussoirs s'enclenchent dans les trous.

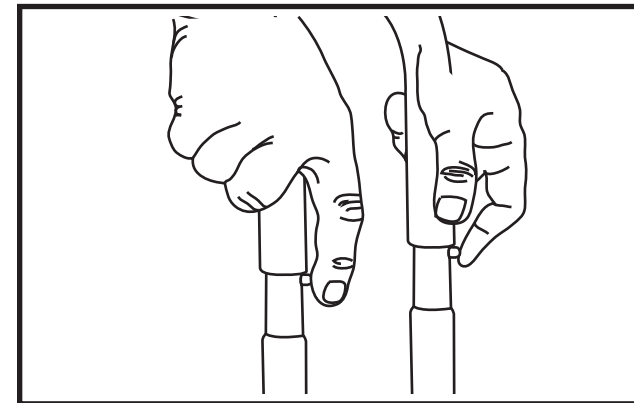

B Ajouter / Voir pétrole
 Le moteur est livré sans huile. Avant de démarrer le moteur, ajouter l'huile fournie. Vérifier le niveau d'huile avant chaque utilisation. Consultez le guide du moteur pour connaître la procédure appropriée

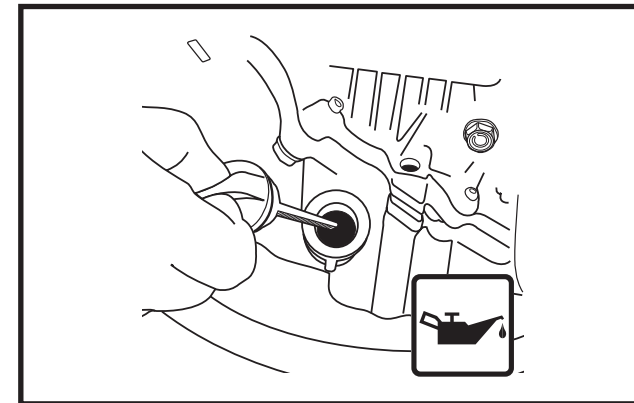

C Ajouter l'essence
 Dans un endroit extérieur bien aéré, ajoutez de l'essence pure, sans plomb, de haute qualité et ayant un indice d'octane de 86 ou plus. Ne pas trop remplir. Essayez l'essence déversée avant de démarrer le moteur. Consultez le guide du moteur pour connaître la procédure appropriée

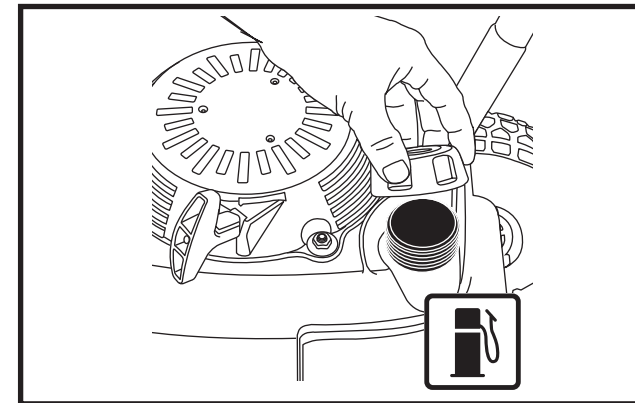

IMPORTANT: Ethanol Shield™ (vendu séparément) est un stabilisateur de carburant qui aide à éliminer et à prévenir les problèmes liés à l'éthanol dans les équipements de puissance. Suivez les instructions sur le contenant et ajouter à l'essence.

GUIDE DE DÉMARRAGE RAPIDE

(Numbers 1-11)

Danger:

- Ne faites jamais tourner le moteur à l'intérieur ou dans un endroit clos, mal aéré. Les émanations d'échappement contiennent du monoxyde de carbone, un gaz inodore et mortel.
- Risque d'injection de liquide et de laceration. Lorsque vous utilisez le réglage à haute pression, NE LAISSEZ PAS le jet à haute pression entrer en contact avec la peau non protégée ou des animaux de compagnie ou autres. Des blessures sérieuses surviendront.

1 Branchez le tuyau d'arrosage à la pompe
 Filetez le tuyau d'arrosage à l'entrée de la pompe.

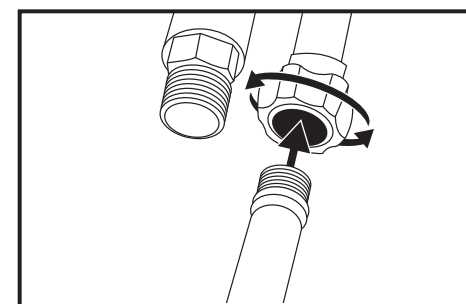

2 Branchez le tuyau d'arrosage à la pompe
 Filetez le tuyau à haute pression à la sortie de la pompe

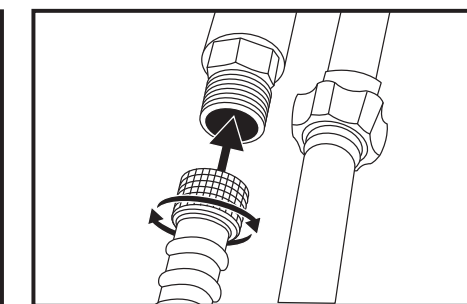

3 Branchez la lance d'arrosage au pistolet de pulvérisation
 Filetez la lance d'arrosage dans l'extrémité du pistolet de pulvérisation.

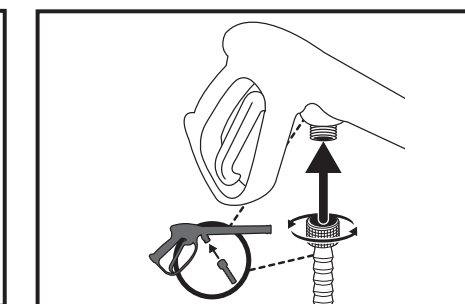

4 Branchez la lance d'arrosage au pistolet de pulvérisation
 Thread the spray wand into the end of the spray gun.

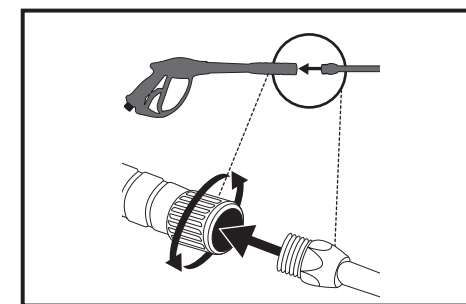

5 Branchez la lance d'arrosage au pistolet de pulvérisation
 Filetez la lance d'arrosage dans l'extrémité du pistolet de pulvérisation.

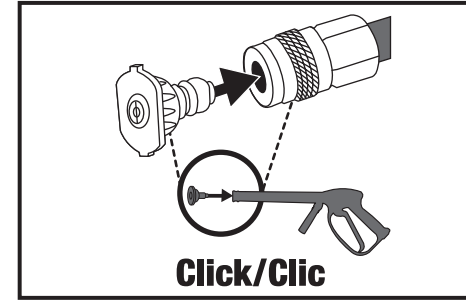

6 Ouvrez le robinet d'eau au complet
 Ne faites pas fonctionner l'appareil si l'alimentation d'eau n'est pas branchée et ouverte. Utilisez uniquement de l'eau froide.

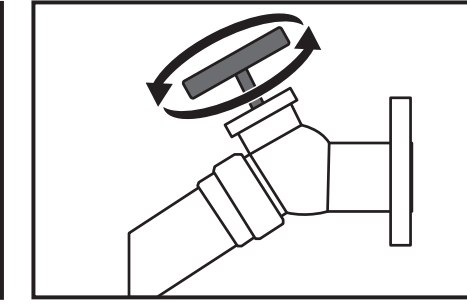

7 Relâchez l'air du système
 Relâchez tout l'air de la pompe et du tuyau à haute pression en appuyant sur la gâchette jusqu'à ce qu'un écoulement constant d'eau soit présent. Environ 30 secondes.

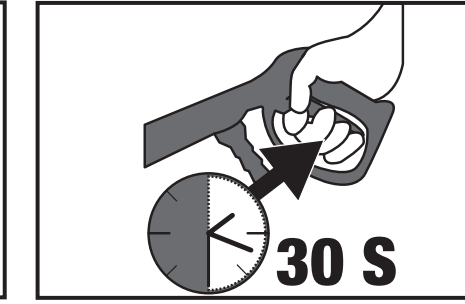

8 Assurez-vous que l'interrupteur du moteur soit à la position MARCHÉ (ON)

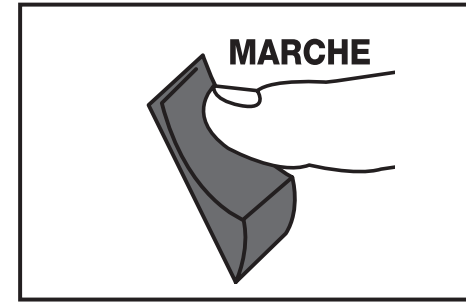

9 Assurez-vous que la tige du volet de départ soit tirée à la position CHOKE

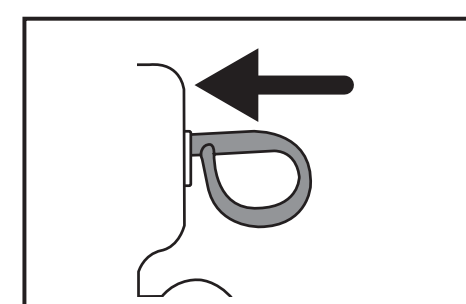

10 Tirez la poignée du lanceur
 Tirez la poignée du lanceur pour faire démarrer le moteur.

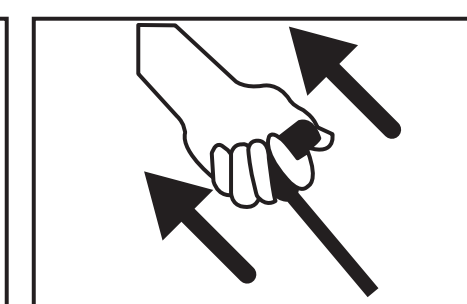

11 Poussez la tige du volet de départ à la position MARCHÉ
 Déplacez, de façon graduelle, la tige du volet de départ à la position MARCHÉ lorsque le moteur démarre.

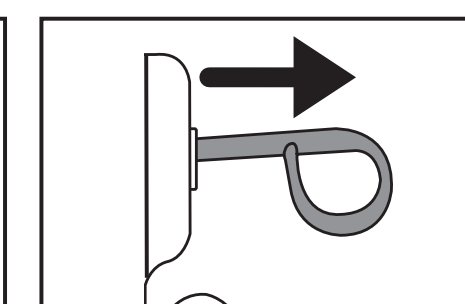

AVERTISSEMENT: Ce guide n'est pas un substitut pour la lecture du manuel d'utilisation. Vous devez lire et comprendre le manuel de l'opérateur avant d'utiliser ce produit.