



To obtain a full manual, including your warranty terms, scan the code or text the number on the Learn More label on the machine, or visit <https://www.simpsoncleaning.com>, or contact Customer Support at 1-877-362-4271 or email: cservice@fna-group.com



SCAN QR CODE OR TEXT
MODEL #
TO 1 (888) 123-
SAMPLE

Notes:

1. This quick start guide is not a replacement for the owner's manual. **Be sure to download and read the owners manual before operating the machine for the first time.**
2. Read all the information in the safety section of this document and all related user manuals before operating the machine.
3. Perform the procedures outlined in this quick start guide before operating the machine.

Contact Us:

If you have any questions regarding the unpacking, assembly, or use of your pressure washer, please have your model number and serial number ready, then contact customer support at **1-877-362-4271** or email cservice@fna-group.com.

Disclaimers:

- All information in this guide was based on the latest product information available at the time of its printing.
- This guide may cover more than one machine. The drawings in this guide should be used for reference only. There may be differences between your product and the pictures, drawings, and / or diagrams used in this guide.
- In a continued commitment to improve quality, The manufacturer reserves the right to update, change, and / or improve the product(s) covered in this guide at any time, without notice, and without incurring any obligation. Therefore, the product(s) this guide covers may differ slightly those pictured.

Safety: **NOTE:** Be sure to read understand the safety information listed below. Each box contains one of three words: WARNING, CAUTION, or NOTICE each of these words indicates a different level of hazard severity and is followed by information about specific hazards, the consequences of the hazards, and instructions on how to avoid the hazards. Failure to heed these symbols and the information provided with them could result in property damage, injury, and/or death.

WARNING: Indicates a potentially hazardous situation which, if not avoided, could result in property damage, serious injury, and/ or death.

CAUTION: Indicates a hazardous situation, which if not avoided, could result in property damage and/or minor to moderate injury.

NOTICE Indicates information considered important but not directly hazard related.

WARNING: OPERATION CHECKLIST
Attempting to start the engine incorrectly or using the pressure washer incorrectly can result in engine and/ or pressure washer damage, and may cause serious injury or death. To avoid these hazards, be sure to read, understand, and follow the steps outlined in the OPERATING CHECKLIST section of the owner's manual before starting the engine, and follow all the guidelines for proper use of the pressure washer.

WARNING: UNTRAINED OPERATION
Untrained persons, young children, and pets can be seriously injured or killed if allowed to incorrectly operate or play with a running pressure washer. To avoid these hazards, be sure anyone operating the pressure washer receives proper instructions, understands safe operation, and has read the owner's manual before operating this product. Do not let children operate the pressure washer without parental supervision. Keep young children and pets away from the pressure washer while it is running. Always turn off the pressure washer before leaving the area.

WARNING: TRANSPORTATION
Transporting the pressure washer in an enclosed space on a transport vehicle where temperatures can rise may cause fuel to vaporize and leak. Gasoline is highly flammable and gasoline vapors are extremely explosive. Fire and explosions can cause severe burns and/or death. To avoid these hazards, secure the pressure washer in a well ventilated area out of direct sunlight and other heat sources and do not transport the pressure washer on rough roads unless the fuel has been drained beforehand.

WARNING: MOVING PARTS
This product has many parts that move at high speeds. Moving parts can cause crushing injuries, broken bones, severe lacerations, and/or traumatic amputations. To prevent injury, never place fingers, hands, feet, or other body parts near running engine. Never operate product with covers, shrouds, or other guards removed. Do not wear loose-fitting clothing, dangling drawstrings, or any other hanging items that could become entangled in moving parts while operating. Tie up long hair and remove jewelry before operating.

WARNING: REFUELING
Gasoline is highly flammable and gasoline vapors are extremely explosive. Fire and explosions can cause severe burns and/or death. Keep gasoline away from flames, sparks, and other ignition sources. Refuel outdoors in a well-ventilated area with the engine stopped and cool. Wipe up any spilled gasoline and allow engine to dry before starting. Keep a fire extinguisher handy while refueling. Do not operate engine with leaks in the fuel system. Do not store gasoline near other flammable materials.

WARNING: VOLATILE LIQUIDS
Pressure washing with volatile, flammable, or corrosive liquids could cause pressure washer damage, fire, or explosion resulting in severe injury and/or death. To avoid these hazards, use only approved soaps and chemicals, do not attempt to pressure wash with volatile, flammable, or corrosive liquids, and NEVER use bleach.

WARNING: INSPECT
Failure to inspect this product and before use could result in product damage, serious injury, and/or death. To avoid these hazards, inspect the pressure washer before each use. Check for loose or damaged parts, signs of oil or fuel leaks, missing guards, plugged cooling vents, or any other condition that may affect proper operation. Repair or replace all damaged or defective parts and keep all safety guards in place and in proper working order before using the pressure washer.

WARNING: TOXIC FUMES
Engine exhaust contains carbon monoxide, an odorless, colorless, poisonous gas. Running an engine indoors will kill you in minutes. Never use this product inside a house, garage, or any other kind of enclosure even if doors and windows are open. Run engine outside at least 20 feet (6 meters) away from windows, doors, and vents. Carefully consider wind direction and air currents when using this product outside to avoid breathing in engine exhaust. Always use a carbon monoxide detector in any occupied buildings near the running engine.

WARNING: INJECTION INJURY
The high pressures created by a pressure washer can cause fluid injection injuries, severe lacerations, amputations, and / or death. To avoid these hazards, always aim the spray gun and lance in a safe direction when using a pressure washer and never attempt to touch a leak in a high-pressure hose or fitting.

⚠ WARNING: RAPID RETRACTION

Rapid retraction (also known as kickback) of the engine recoil starter cord will pull your hand and arm towards the engine faster than you can let go of the handle resulting in sprains, broken bones, lacerations, and/or traumatic amputations. Kickback is caused by damage to the engine crankshaft key, compression release failure, and/or improper starting techniques. To avoid kickback follow the appropriate maintenance schedule and starting instructions listed in the owner's manual and have engine repair work done by an authorized service center.

⚠ CAUTION: HOT SURFACES

A running engine produces heat. The surfaces of the engine, other related components, and engine exhaust gas get hot enough to cause mild moderate burns or ignite materials on contact. To avoid burns, do not touch engine surfaces or exhaust gases while operating and allow engine to cool completely before moving, touching, or performing any maintenance. To avoid a fire, keep all flammable materials at least five feet away from all sides of the product.

⚠ CAUTION: HOT OIL

Hot oil can cause serious burns. To prevent getting burned when changing or checking the engine oil, use gloves to prevent hot oil from touching skin and change oil when the engine is warm from but not hot.

NOTICE CHEMICAL CLEANERS

Using chemical cleaners and/or corrosive liquids can damage the pressure washer seals and internal components. Damage caused by chemical cleaners and corrosive liquids is not covered under warranty. To avoid these hazard, only used approved cleaning chemicals, never use bleach, and always run clean water through the pressure washer after using cleaning chemicals.

NOTICE GASOLINE ADDITIVES

The use of fuel system cleaning additives can damage the engine and fuel systems. Damage caused by the use of fuel system cleaning additives is not covered by warranty. To avoid engine and fuel system damage, do not use any fuel system cleaning additives.

NOTICE

This appliance is not intended to be used by persons (including children) with reduced physical, sensory, or mental capabilities, or lack of experience and knowledge, unless they have been given supervision or instruction concerning use of the appliance by a person responsible for their safety.

Children should be supervised to ensure that they do not play with the appliance.

**CALIFORNIA PROPOSITION 65 WARNING**

This product and the engine exhaust can expose you to chemicals which are known to the state of California to cause cancer, birth defects, or other reproductive harm. For more information on California Proposition 65, go to www.P65Warnings.ca.gov.

NOTICE LOW OIL SENSOR

The low oil sensor (if equipped) will automatically stop the engine when the oil level falls below the safe limit. To avoid an unexpected shutdown, check the oil level regularly, fill to the upper limit, and always operate engine on a level surface.

NOTICE FILL ENGINE OIL BEFORE USING

The engine is shipped from the factory without oil. Running the engine without oil will result in severe engine damage and void the warranty. To avoid causing engine damage and voiding the warranty, fill the engine with the recommended oil type.

NOTICE USE CORRECT ENGINE OIL

Oil is a major factor in the performance and service life of any engine. Using the incorrect oil may damage the engine and void the warranty. To avoid causing engine damage and voiding the warranty, check and change oil as required using the correct engine oil.

NOTICE PUMP DAMAGE

Turning off the water supply to your pump with the engine running will damage the pump. Damage caused by running the pump without water is not covered under warranty. To avoid this hazard always turn off the engine before shutting off the water supply.

NOTICE OLD GASOLINE

Old gasoline can create deposits that clog fuel systems causing hard starting and poor performance. Damage caused by old fuel is not covered by warranty. To minimize deposits, avoid old fuel related performance issues, and prevent costly repair work, do not use gasoline that is older than 30 days.

NOTICE ALCOHOL BLENDS

Using gasoline with an alcohol blend greater than 10% (E10) will damage the engine. Damage caused by using an alcohol blend of 15% (E15), 85% (E85), or any other alcohol blend higher than 10% (E10) is not covered under warranty. To avoid engine damage caused by an alcohol blend that is too high, use gasoline with 10% (E10) alcohol or lower.

NOTICE DO NOT OVERFILL FUEL TANK

Overfilling the fuel tank can result in carbon canister damage (if equipped), poor engine performance, and void the warranty. To avoid these hazards, do not fill the fuel tank above the maximum level.

NOTICE PUMP PURGING

Running a pressure washer pump without water will severely damage the pump seals and other internal components. To avoid this hazard, make sure your water supply is uninterrupted, provides at least 5 GPM at 20 PSI, and always purge the air your pressure washer pump before starting the engine.

Refer to the 'Assembly / Connecting Hoses' section of this quick-start guide to learn how to purge the pump of air.

NOTICE SPRAY DAMAGE

High-pressure spray can damage plants and other surfaces. To avoid damaging plants, cover them before spraying near them. To avoid damaging surfaces. Refer to the Nozzle Selection table in this manual for correct nozzle and test surfaces before spraying to make sure they are strong enough to withstand high-pressure spray.

NOTICE ALTITUDE

Operating the engine with a high-altitude carburetor jet kit at an altitude below 5000 feet (1524 meters) will cause the engine to run too hot. Overheating the engine could result in serious engine damage. To avoid this hazard, make sure the correct carburetor kit is installed and the air/fuel mixture is set correctly for your altitude.

NOTICE CLEANING

Water can damage the pressure washer engine components if allowed to enter through cooling slots or other holes. Damage caused by water intrusion is not covered under warranty. To avoid engine water damage, do not use a pressure washer, garden hose, or any other sources of running water to clean the pressure washer engine, and never submerge the pressure washer engine in any liquids.

NOTICE GASOLINE STORAGE

It is important to prevent gum deposits from forming in essential fuel system parts, such as the carburetor, fuel filter, fuel hose or tank during storage. Alcohol-blended fuels (also called gasohol, ethanol, or methanol) attract moisture, which leads to separation and formation of acids during storage. Acidic fuel and gum deposits can damage the engine's fuel system while in storage. Damage caused by the use of old, stale, or contaminated fuel are not covered under warranty.

NOTICE PUMP DAMAGE

Running the pressure washer for more than two minutes without the spray gun trigger pulled will overheat the pump and possibly cause damage. The thermal relief valve will open and spray water to help cool the pump as it overheats. To avoid overheating the pump, shut off the machine if not being used for longer than two minutes.

NOTICE FREEZE DAMAGE

Anytime the pressure washer may endure freezing temperatures, remaining water needs to be drained from the pump, high-pressure hose and spray gun assembly. Drain the hose, spray gun and pump as explained in the pressure washer Use and Care Manual. It is suggested to purge the pump of water by using Simpson® Pump Guard or equivalent pump protectant.

Unpacking:

1. Place the shipping carton on a solid, flat surface.
2. Carefully cut the top of the carton open.
3. Carefully cut each corner of the carton from top to bottom.
4. Lay each side of the carton flat on the ground.
5. Remove everything from the carton.

Assembly / Connecting Hoses:

1. Press and hold buttons then slide handle onto frame until buttons click into place.

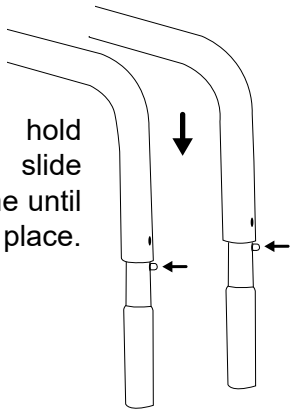

OR

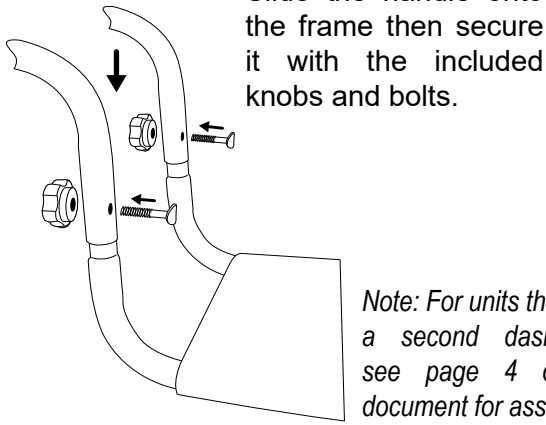

Slide the handle onto the frame then secure it with the included knobs and bolts.

Note: For units that have a second dashboard, see page 4 of this document for assembly.

2. Install the spray gun holster (if applicable) onto the handle using the included knob and bolt.

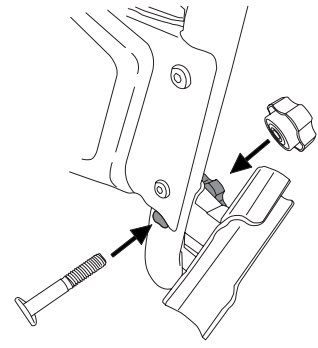

3. Make sure the inlet screen is clean, inside the pump inlet, and has the convex side facing out.

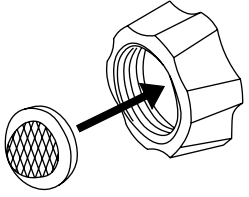

4. Turn on the water supply and run it for 30 seconds to purge any dirt or debris from the supply hose. Then, turn off the water supply and thread the water supply hose into the pump inlet.

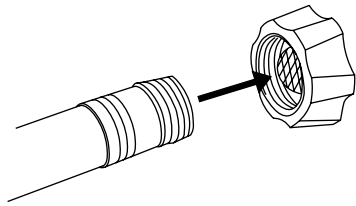

5. Insert the male quick-connect (QC) plug on the high-pressure hose into the female QC outlet on the pump or thread the high-pressure hose onto the pump outlet.

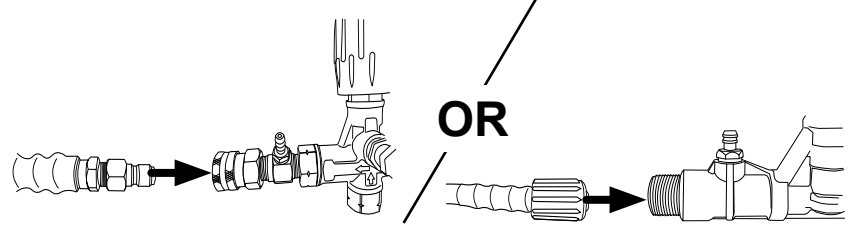

6. Insert the male QC plug on the spray gun into the female QC connector on the high-pressure hose.

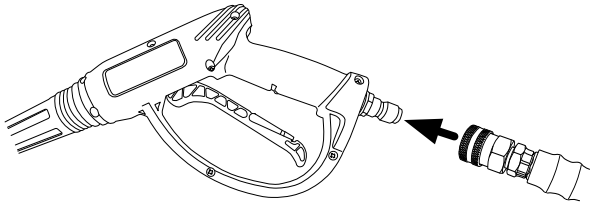

Thread the high-pressure hose onto the spray gun inlet.

OR

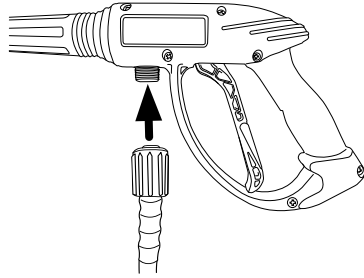

Thread the high-pressure hose onto the spray gun inlet.

OR

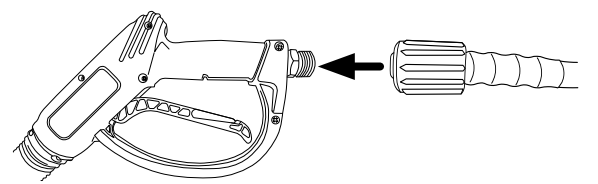

7. Secure the lance to the gun by carefully turning the coupler on the spray gun until the coupler stops rotating. Do not over tighten. Most of the threads on the lance will not be visible if the lance and gun are properly assembled. Be careful not to cross-thread the gun and lance.

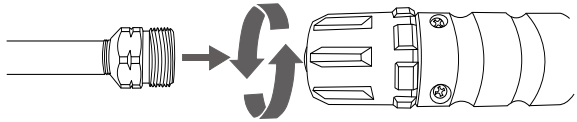

8. Turn on the water supply, aim the spray gun in a safe direction, then squeeze and hold the trigger for at least 30 seconds or until the water runs steady and all the air is purged from the pump and hoses. When completed, engage the trigger lock.

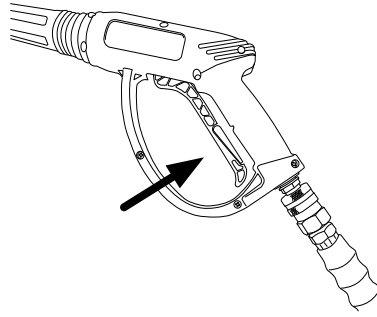

9. Select the correct nozzle for your cleaning job per nozzle selection chart in this document and install it onto the lance by pulling the quick-connect coupler back, inserting the nozzle, then releasing the coupler allowing it to snap back in place.

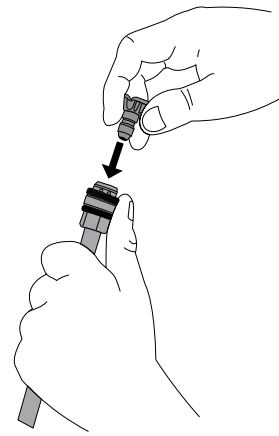

WARNING! The threads on the lance and gun coupler can be easily cross threaded resulting in an improper assembly. An improper assembly of the gun and lance can result in personal injury. Do not use if the threads on the gun coupler and or lance are cross threaded.

10. Remove fuel cap, fill fuel tank with fresh gasoline, then replace fuel cap. Be careful not to cross-thread the gun and lance.

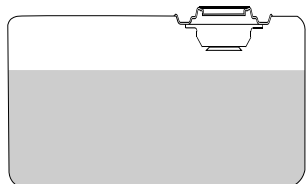

NOTE: Fill with engine off and cool. Do not over fill fuel tank.

Fill Engine With Oil:

NOTICE

This pressure washer was shipped from the factory without oil in the engine. Running the engine without oil will result in severe engine damage and void the warranty. To avoid these hazards, fill the engine with the recommended oil type before starting.

2. Fill the engine with the correct oil per the engine owner's manual. The oil level should be towards the high mark on the dipstick. Replace the dipstick when the engine is full.

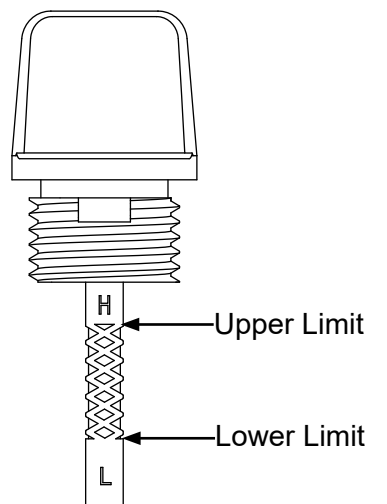

OR

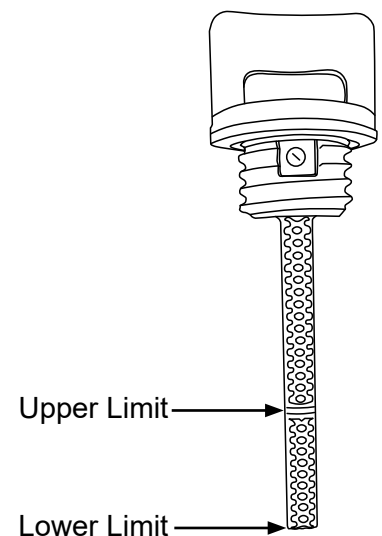

1. Place machine on a level surface then remove the engine oil dipstick by unscrewing it.

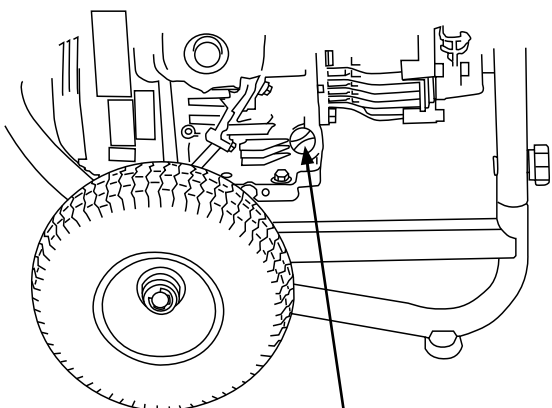

Engine Oil Dipstick

OR

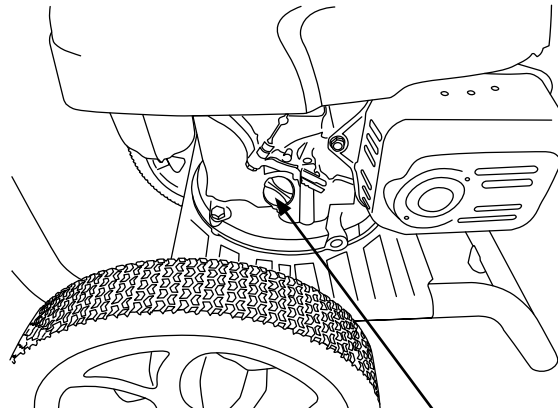

Engine Oil Dipstick

Starting:

1. Turn the engine ignition switch and the fuel valve to their ON positions.

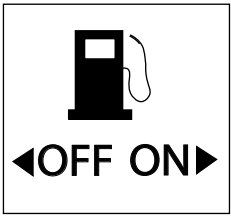
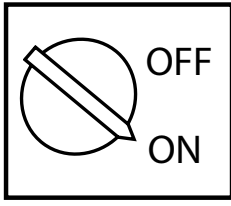

2. Adjust choke as needed.

CLOSED

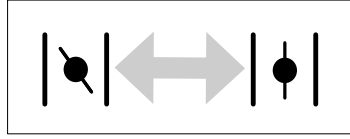

OPEN

NOTE: The starting position of the choke will vary depending on the engine temperature. If starting a cold engine, move the choke lever towards the closed position. If starting a warm engine, move the choke lever towards the open position. Once the engine warms up from running, you may need to adjust choke towards the open position until idle is smooth.

3. Pull the recoil slowly until resistance is felt, then pull rapidly to start the engine.

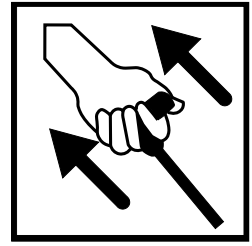

4. Allow engine to warm for 1-2 minutes before using the product.

Using Chemicals:

1. Attach the open end of the soap hose to the barbed fitting on the pump.

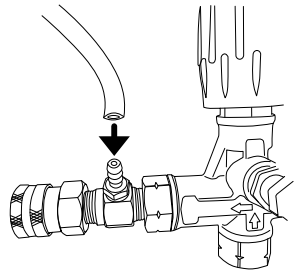

2. Place the filtered end of the soap hose into a container of soap or fill the soap tank

NOTE: Use only soaps that are approved for pressure washer use.



OR

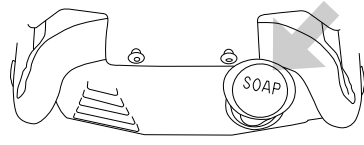

3. If the engine is running, make sure the trigger lock is in the locked position before removing and installing nozzles.

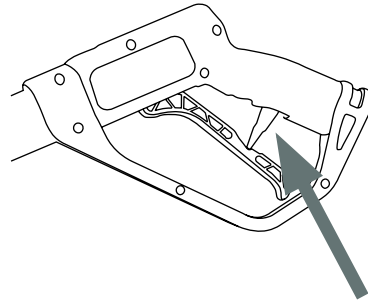

4. Insert the black nozzle into the spray wand.

NOTE: Soaps will not siphon if the black soap nozzle is not installed on the spray wand.

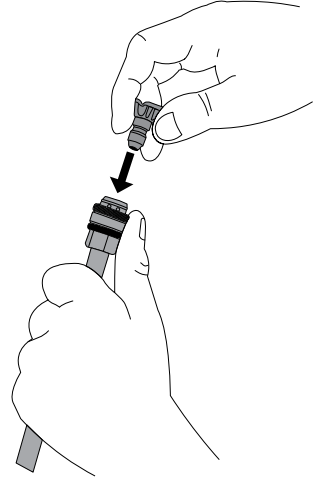

NOTE: After using soap, place the filtered end of the soap hose into a container of clean water and run pressure washer drawing clean water through the hose and pump until the system is thoroughly rinsed. If soap or other chemicals remain in the pump, the pump could be damaged. Pump damage from soap or chemical residue is not covered under warranty.

Dual Dashboard Assembly: (If applicable)

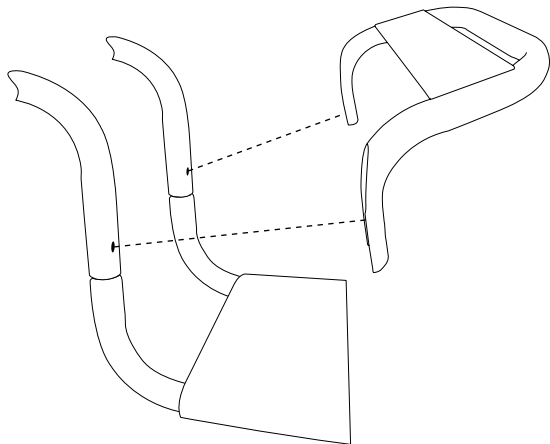

1. Place the second dashboard on the handle making sure to line up the holes in both the handle and the second dashboard.

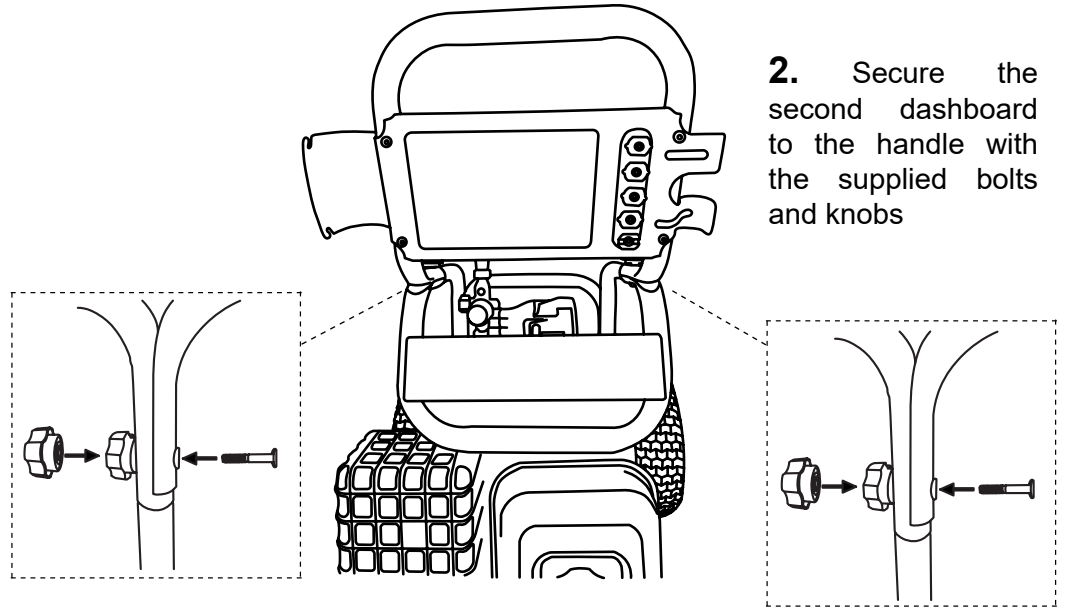

2. Secure the second dashboard to the handle with the supplied bolts and knobs

Selecting a Nozzle:

Color	Spray Pattern	Uses	Surfaces
Red	0°	Spot cleaning hard, unpainted surfaces and high-reach areas	Unpainted metal and concrete DO NOT use on wood
Yellow	15°	Intense cleaning of unpainted surfaces	Grills, driveways, concrete and brick walkways, unpainted brick and stucco
Green	25°	Standard cleaning nozzle for most applications	Yard tools, sidewalks, lawn furniture, unpainted siding, stucco, gutters, eaves, concrete, and brick surfaces
White	40°	Cleaning painted or delicate surfaces	Autos, trucks, RVs, boats, wood, painted brick, painted stucco, vinyl, and painted siding
Black	Soap	Applying cleaning solutions	Safe on all surfaces. Always verify compatibility of cleaning solutions prior to use.

NOTE: Always make sure the nozzle is properly installed by tugging on it after inserting it into the quick connector before using the pressure washer.

Pressure Washing Tips:

1. Set the trigger lock on the spray gun when not in use.
2. A wider spray equals faster cleaning, while tighter spray equals deeper cleaning.
3. Do not aim the nozzle straight at a surface. Hold the wand at a 45-degree angle to the surface and at a distance that cleans well without causing damage.
4. Keep the nozzle about 4-feet away from siding to prevent damage to surfaces.
5. Wash siding by starting at the bottom and working your way up, then rinse from the top down.
6. Avoid driving water up behind siding.
7. For even cleaning, use overlapping strokes.
8. Work in smaller areas and do not let soap dry on surfaces.
9. Whenever freezing weather is possible, remove any remaining water from the high-pressure hose, spray gun assembly and the pump as indicated in the pressure washer Use and Care Manual. We suggest protecting the pump by using Simpson® Pump Guard.