



SIMPSON

4000 PSI

4.0 GPM

## INSTRUCTION MANUAL

## KING BRUTE 2.0 MODELS 65132 and 65133

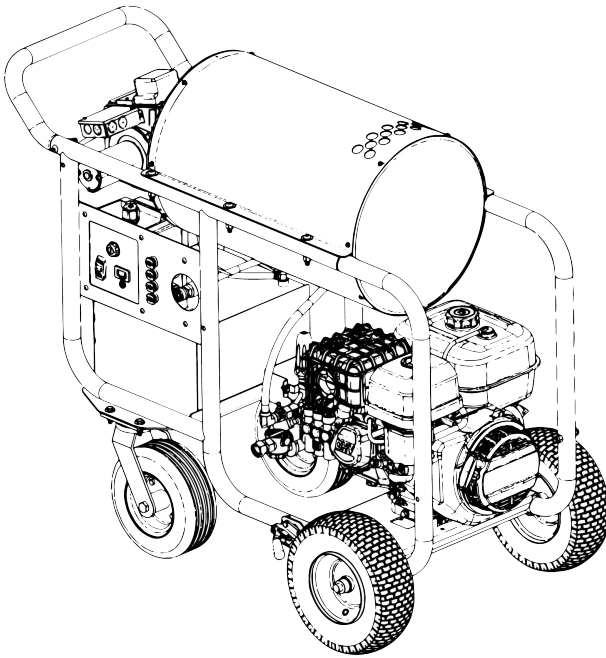

### LOOK BEFORE YOU PUMP!

Ethanol Percentage

<10% OK NO 15%—30%—85%

DO NOT USE FUEL CONTAINING  
GREATER THAN 10% ETHANOL!

N'UTILISEZ PAS UN CARBURANT DONT LA  
TENEUR EN ÉTHANOL EST SUPÉRIEURE À 10%!

¡NO UTILICE COMBUSTIBLES QUE  
CONTENGAN MÁS DE 10% DE ETANOL!

If your pressure washer is not working properly or if there are parts missing or broken, please **DO NOT RETURN IT TO THE PLACE OF PURCHASE**. Contact our Customer Service Department at **1-844-375-7577**.

**IMPORTANT:** Please make certain that the person who is to use this equipment carefully reads and understands these instructions before operating.

**SAVE THIS MANUAL FOR FUTURE REFERENCE**

## TABLE OF CONTENTS

---

---

Safety Guidelines - Definitions .....	3
Important Safety Instructions .....	3
Get to Know the Pressure Washer .....	9
Basic Elements of a Pressure Washer .....	9
Basic Elements of a Pump .....	10
Basic Elements of an Engine .....	10
Operation .....	12
Pressure Washer Operating Features .....	12
Starting.....	14
Before Each Start Up .....	14
Shutting Down) .....	16
Maintenance .....	16
Storage .....	17
Engine .....	17
Pressure Washer.....	17
Accessories.....	18
Specifications.....	18
Service Information.....	18
Troubleshooting Guide.....	19
Limited Warranty.....	23

## SAFETY GUIDELINES - DEFINITIONS

---

---

This manual contains information that is important for you to know and understand. This information relates to protecting YOUR SAFETY and PREVENTING EQUIPMENT PROBLEMS. To help you recognize this information, we use the symbols below. Please read the manual and pay attention to these symbols.

**⚠ DANGER:** Indicates an imminently hazardous situation which, if not avoided, will result in **death or serious injury**.

**⚠ WARNING:** Indicates a potentially hazardous situation which, if not avoided, could result in **death or serious injury**.

**⚠ CAUTION:** Indicates a potentially hazardous situation which, if not avoided, may result in **minor or moderate injury**.

**NOTICE:** Indicates a practice **not related to personal injury** which, if not avoided, may result in **property damage**.

## IMPORTANT SAFETY INSTRUCTIONS

---

---

If you loan, rent, or sell this machine, be sure to include all instructional materials with the unit!

**⚠ DANGER: Carbon Monoxide.** Using an engine indoors can kill you in minutes. Engine/burner exhaust contains high levels of carbon monoxide (CO), a poisonous gas you cannot see or smell. You may be breathing CO even if you do not smell engine exhaust.

- **NEVER** use an engine or oil burner inside homes, garages, crawlspaces or other partly enclosed areas. Deadly levels of carbon monoxide can build up in these areas. Using a fan or opening windows and doors does **NOT** supply enough fresh air.
- **ONLY** use outdoors and far away from open windows, doors and vents. These openings can pull in engine exhaust. Never operate the pressure washer in or near a location occupied by humans or animals.
- Even when the engine is used correctly, CO may leak into your home. **ALWAYS** use a battery-powered or battery backup CO alarm in your house. **Read and follow all directions for CO alarm before using.** If you feel sick, dizzy or weak at anytime, move to fresh air immediately. See a doctor. You could have carbon monoxide poisoning.

**⚠ WARNING:** Do not operate this unit until you read this instruction manual and the engine instruction manual for safety, operation and maintenance instructions. **If you have any questions regarding the product, please contact our customer service department at 1-844-375-7577.**

**⚠ DANGER: Risk of injection or severe injury. Keep clear of nozzle. Do not direct discharge stream at persons or live animals. This product is to be used only by trained operators.**

**⚠ WARNING:** This product and its exhaust contain chemicals known to the State of California to cause cancer, birth defects or other reproductive harm. In addition, some cleaning products and dust contain chemicals known to the State of California to cause cancer, birth defects or other reproductive harm. **Wash hands after handling.**

**⚠ WARNING:** This product may not be equipped with a spark-arresting muffler. If the product is not equipped and will be used around flammable materials or on land covered with materials such as agricultural crops, forest, brush, grass or other similar items, then an approved spark arrester must be installed and is legally required in the state of California. It is a violation of California statutes section 130050 and/or sections 4442 and 4443 of the California Public Resources Code, unless the engine is equipped with a spark arrester, as defined in section 4442, and maintained in effective working order. Spark arresters are also required on some U.S. Forest Service land and may also be legally required under other statutes and ordinances.

## SAVE THESE INSTRUCTIONS



**⚠ DANGER: RISK OF EXPLOSION OR FIRE**

WHAT CAN HAPPEN	HOW TO PREVENT IT
<ul style="list-style-type: none"> <li>Spilled gasoline (diesel, kerosene, approved alternate fuel) and it's vapors can become ignited from cigarette sparks, electrical arcing, exhaust gases and hot engine components such as the muffler.</li> </ul>	<ul style="list-style-type: none"> <li>Shut off engine and allow it to cool before adding fuel to the tank.</li> <li>During refueling all ignition sources and switches should be in the OFF position.</li> <li>Use care in filling tank to avoid spilling fuel. Move pressure washer away from fueling area before starting engine.</li> </ul>
<ul style="list-style-type: none"> <li>Heat will expand fuel in the tank which could result in spillage and possible fire or explosion.</li> </ul>	<ul style="list-style-type: none"> <li>Keep maximum fuel level 1/2" (12.7 mm) below bottom of filler neck to allow for expansion.</li> </ul>
<ul style="list-style-type: none"> <li>Operating the pressure washer in an explosive environment could result in a fire.</li> </ul>	<ul style="list-style-type: none"> <li>Operate and fuel equipment in well-ventilated areas free from obstructions. Equip areas with fire extinguisher suitable for gasoline fires.</li> </ul>
<ul style="list-style-type: none"> <li>Materials placed against or near the pressure washer can interfere with its proper ventilation features causing overheating and possible ignition of the materials.</li> </ul>	<ul style="list-style-type: none"> <li>Never operate pressure washer in an area containing dry brush or weeds.</li> </ul>
<ul style="list-style-type: none"> <li>Improperly stored fuel could lead to accidental ignition. Fuel improperly secured could get into the hands of children or other unqualified persons.</li> </ul>	<ul style="list-style-type: none"> <li>Store engine and burner fuel in a clean OSHA approved container, in a secure location away from work area. Do not allow debris or moisture to enter container.</li> </ul>
<ul style="list-style-type: none"> <li>Spraying of gasoline, kerosene or any kind of flammable solvent with this product could result in serious injury or death.</li> </ul>	<ul style="list-style-type: none"> <li>Do not spray flammable liquids.</li> </ul>
<ul style="list-style-type: none"> <li>Flammable liquids can create fumes which can ignite, causing property damage or serious injury.</li> </ul>	<ul style="list-style-type: none"> <li>Operate only where open flame or torch is permitted.</li> </ul>



**⚠ DANGER: RISK TO BREATHING (ASPHYXIATION)**

<b>WHAT CAN HAPPEN</b>	<b>HOW TO PREVENT IT</b>
<ul style="list-style-type: none"> <li>Breathing exhaust fumes will cause serious injury or death! Engine exhaust contains carbon monoxide, an odorless and deadly gas.</li> </ul>	<ul style="list-style-type: none"> <li>Operate pressure washer in a well-ventilated area. Avoid enclosed areas such as garages, basements, etc.</li> <li>Never operate unit in or near a location occupied by humans or animals.</li> <li>Never connect pressure washer to a TYPE B gas vent.</li> </ul>
<ul style="list-style-type: none"> <li>Some cleaning fluids contain substances which could cause injury to skin, eyes or lungs.</li> </ul>	<ul style="list-style-type: none"> <li>Use only cleaning fluids specifically recommended for high pressure washers. Follow manufacturers recommendations. Do not use chlorine bleach or any other corrosive compound.</li> </ul>



**⚠ DANGER: RISK OF FLUID INJECTION AND LACERATION**

<b>WHAT CAN HAPPEN</b>	<b>HOW TO PREVENT IT</b>
<ul style="list-style-type: none"> <li>Your pressure washer operates at fluid pressures and velocities high enough to penetrate human and animal flesh which could result in amputation or other serious injury. Leaks caused by loose fittings or worn or damaged hoses can result in injection injuries. <b>DO NOT TREAT FLUID INJECTION AS A SIMPLE CUT!</b> See a physician immediately!</li> </ul>	<ul style="list-style-type: none"> <li>Inspect the high pressure hose regularly. Replace the hose immediately if it is damaged, worn, has melted from contacting the engine, or shows any signs of cracks, bubbles, pinholes, or other leakage. Never grasp a high pressure hose that is leaking or damaged.</li> <li>Never touch, grasp or attempt to cover a pinhole or similar water leak on the high pressure hose. The stream of water IS under high pressure and WILL penetrate skin.</li> <li>Never place hands in front of nozzle.</li> <li>Direct spray away from self and others.</li> <li>Make sure hose and fittings are tightened and in good condition. Never hold onto the hose or fittings during operation.</li> <li>Do not allow hose to contact muffler.</li> <li>Never attach or remove wand or hose fittings while system is pressurized.</li> <li>When using replacement lances or guns with this pressure washer, DO NOT use a lance and/or lance/gun combination that is shorter in length than what was provided with this pressure washer as measured from the nozzle end of the lance to the gun trigger.</li> <li>Use only accessories rated equal to or higher than the rating of the pressure washer.</li> </ul>

- Injuries can result if system pressure is not reduced before attempting maintenance or disassembly.
- To relieve system pressure, shut off engine, turn off water supply and pull gun trigger until water stops flowing.



**⚠ DANGER: RISK OF INJURY FROM SPRAY**

<b>WHAT CAN HAPPEN</b>	<b>HOW TO PREVENT IT</b>
<ul style="list-style-type: none"> <li>• High-velocity fluid spray can cause objects to break, projecting particles at high speed.</li> </ul>	<ul style="list-style-type: none"> <li>• Always wear safety glasses. Wear protective clothing to protect against accidental spraying.</li> <li>• Never point wand at or spray people or animals.</li> </ul>
<ul style="list-style-type: none"> <li>• Light or unsecured objects can become hazardous projectiles.</li> </ul>	<ul style="list-style-type: none"> <li>• Always secure trigger lock when wand is not in service to prevent accidental operation.</li> <li>• Never permanently secure trigger in pull-back (open) position.</li> </ul>



**⚠ DANGER: RISK OF UNSAFE OPERATION**

<b>WHAT CAN HAPPEN</b>	<b>HOW TO PREVENT IT</b>
<ul style="list-style-type: none"> <li>• Unsafe operation of your pressure washer could lead to serious injury or death to you or others.</li> </ul>	<ul style="list-style-type: none"> <li>• Do not use chlorine bleach or any other corrosive compound.</li> <li>• Become familiar with the operation and controls of the pressure washer.</li> <li>• Keep operating area clear of all persons, pets and obstacles.</li> <li>• Do not operate the product when fatigued or under the influence of alcohol or drugs. Stay alert at all times.</li> <li>• Never compromise the safety features of this product.</li> <li>• Do not operate machine with missing, broken or unauthorized parts.</li> <li>• Never leave wand unattended while unit is running.</li> <li>• Do not obstruct the burner exhaust.</li> <li>• Do not tamper with the safety pressure relief valve.</li> <li>• Do not tamper with the unloader valve.</li> <li>• Do not modify the pressure washer.</li> </ul>
<ul style="list-style-type: none"> <li>• If proper starting procedure is not followed, engine can kickback causing serious hand and arm injury.</li> </ul>	<ul style="list-style-type: none"> <li>• If engine does not start after two pulls, squeeze trigger of gun to relieve pump pressure. Pull starter cord slowly until resistance is felt. Then pull cord rapidly to avoid kickback and prevent hand or arm injury.</li> </ul>
<ul style="list-style-type: none"> <li>• The spray gun/wand is a powerful cleaning tool that could look like a toy to a child.</li> </ul>	<ul style="list-style-type: none"> <li>• Keep children away from the pressure washer at all times.</li> </ul>

<ul style="list-style-type: none"> <li>Reactive force of spray will cause gun/wand to kickback, and could cause the operator to slip or fall or misdirect the spray. Improper control of gun/wand can result in injuries to self and others.</li> </ul>	<ul style="list-style-type: none"> <li>Do not overreach or stand on an unstable support.</li> <li>Do not use pressure washer while standing on a ladder.</li> <li>Grip gun/wand firmly with both hands. Expect the gun to kickback when triggered.</li> </ul>
---	---



**⚠ DANGER: RISK OF INJURY OR PROPERTY DAMAGE WHEN TRANSPORTING OR STORING**

WHAT CAN HAPPEN	HOW TO PREVENT IT
<ul style="list-style-type: none"> <li>Fuel or oil can leak or spill and could result in fire or breathing hazard. Serious injury or death can result. Fuel or oil leaks will damage carpet, paint or other surfaces in vehicles or trailers.</li> <li>Oil could fill the cylinder and damage the engine if the unit is not stored or transported in an upright position.</li> </ul>	<ul style="list-style-type: none"> <li>If pressure washer is equipped with a fuel shut-off valve, turn the valve to the OFF position before transporting to avoid fuel leaks. If pressure washer is not equipped with a fuel shut-off valve, drain the fuel from tank before transporting. Only transport fuel in an OSHA-approved container.</li> <li>Always place pressure washer on a protective mat when transporting to protect against damage to vehicle from leaks.</li> <li>Always transport and store unit in an upright position. Remove pressure washer from vehicle immediately upon arrival at your destination.</li> </ul>



**⚠ DANGER: RISK OF ELECTRICAL SHOCK**

WHAT CAN HAPPEN	HOW TO PREVENT IT
<ul style="list-style-type: none"> <li>Spray directed at electrical outlets or switches, or objects connected to an electrical circuit, could result in a fatal electrical shock.</li> </ul>	<ul style="list-style-type: none"> <li>Unplug any electrically operated product before attempting to clean it. Direct spray away from electric outlets and switches.</li> </ul>



**⚠ DANGER: RISK OF CHEMICAL BURN**

WHAT CAN HAPPEN	HOW TO PREVENT IT
<ul style="list-style-type: none"> <li>Use of acids, toxic or corrosive chemicals, poisons, insecticides, or any kind of flammable solvent with this product could result in serious injury or death.</li> </ul>	<ul style="list-style-type: none"> <li>Do not spray acids, gasoline, kerosene, or any other flammable materials with this product. Use only household detergents, cleaners and degreasers recommended for use with pressure washers.</li> <li>Wear protective clothing to protect eyes and skin from contact with sprayed materials.</li> </ul>



**⚠ WARNING: RISK OF BURSTING**

<b>WHAT CAN HAPPEN</b>	<b>HOW TO PREVENT IT</b>
<ul style="list-style-type: none"> <li>High-velocity fluid spray directed at pneumatic tire sidewalls (such as found on automobiles, trailers and the like) could damage the sidewall resulting in serious injury.</li> </ul>	<ul style="list-style-type: none"> <li>On pressure washers rated above 1600 psi (11032 kPa) use the widest fan spray (40° nozzle) and keep the spray a minimum of 8" (20 cm) from the pneumatic tire sidewall. Do not aim spray directly at the joint between the tire and rim.</li> </ul>



**⚠ WARNING: RISK OF HOT SURFACES**

<b>WHAT CAN HAPPEN</b>	<b>HOW TO PREVENT IT</b>
<ul style="list-style-type: none"> <li>Contact with hot surfaces, such as engine exhaust components, could result in serious burn.</li> </ul>	<ul style="list-style-type: none"> <li>During operation, touch only the control surfaces of the pressure washer. Keep children away from the pressure washer at all times. They may not be able to recognize the hazards of this product.</li> </ul>
<ul style="list-style-type: none"> <li>Contact with spray will result in serious burn.</li> </ul>	<ul style="list-style-type: none"> <li>DO NOT touch spray, ALWAYS direct spray away from self and others.</li> </ul>

**⚠ WARNING: RISK OF INJURY FROM LIFTING**

<b>WHAT CAN HAPPEN</b>	<b>HOW TO PREVENT IT</b>
<ul style="list-style-type: none"> <li>Serious injury can result from attempting to lift too heavy an object.</li> </ul>	<ul style="list-style-type: none"> <li>The pressure washer is too heavy to be lifted by one person. Obtain assistance from others before lifting.</li> </ul>

**NOTICE: RISK OF PROPERTY DAMAGE**

<b>WHAT CAN HAPPEN</b>	<b>HOW TO PREVENT IT</b>
<ul style="list-style-type: none"> <li>Muffler and burner exhaust heat can damage painted surfaces, melt any material sensitive to heat (such as siding, plastic, rubber, vinyl or the pressure hose, itself), and damage live plants.</li> </ul>	<ul style="list-style-type: none"> <li>Always keep pressure washer a minimum of 4' (1.2 m) away from surfaces (such as houses, automobiles or live plants) that could be damaged from muffler exhaust heat.</li> </ul>

**SAVE THESE INSTRUCTIONS FOR FUTURE USE**



## GET TO KNOW THE PRESSURE WASHER

**NOTE:** Photographs and line drawings used in this manual are for reference only and may not represent your specific model.

Compare the illustrations with your unit to familiarize yourself with the location of various controls and adjustments. Save this manual for future reference.

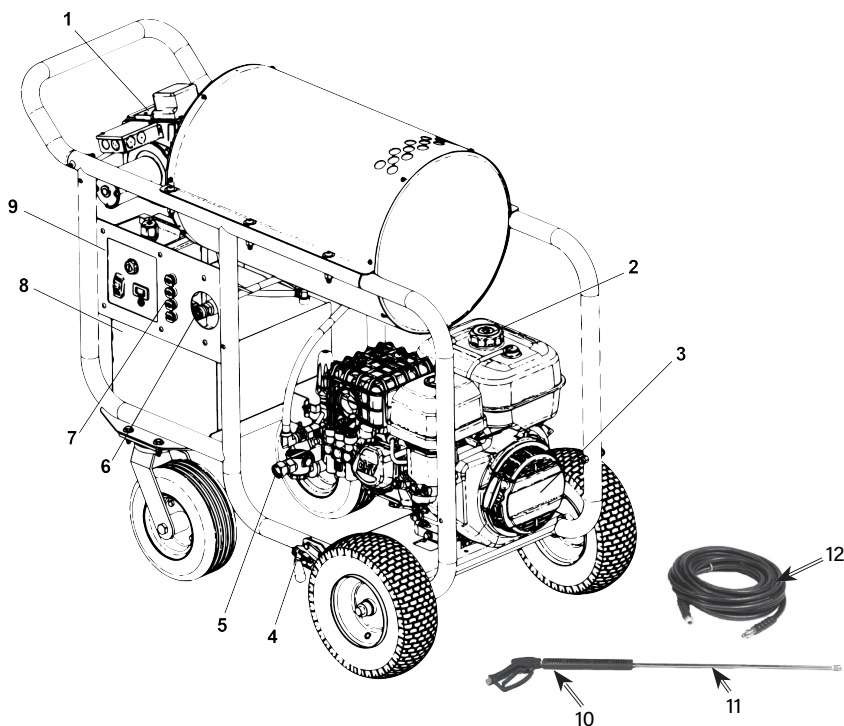

**1. Burner System**

**2. Engine Fuel Fill**

**3. Engine:** See Engine Owner's Manual for more information

**4. Wheel Brake**

**5. Water inlet**

**6. High-Pressure Hot Water Outlet**

**7. Nozzles**

**8. Burner Fuel Tank**

**9. Control Panel**

**10. Spray gun**

**11. Spray wand**

**12. High-pressure hose**

## BASIC ELEMENTS OF A PUMP (FIG. 2)

**NOTICE:** The high-pressure pump was filled with oil at the factory. Always check oil level before using (refer to **Maintenance** for more information).

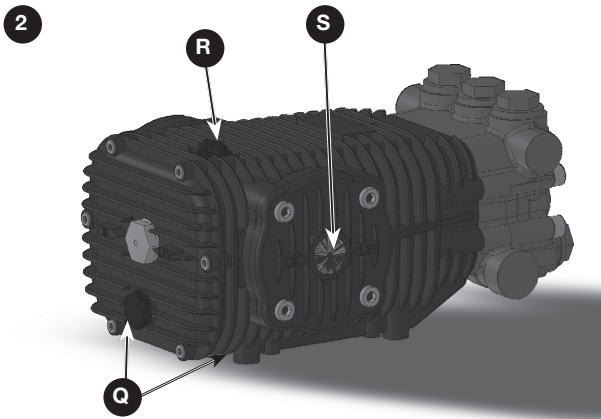

**Q.** Oil drain plug

**R.** Oil fill plug

**S.** Sight glass

## BASIC ELEMENTS OF AN ENGINE

Refer to the **Engine Owner's Manual** for location and operation of engine controls.

**NOTICE:** The engine is shipped without oil. Before starting engine, add the oil provided. Damage to the engine will occur if the engine is run without oil, this damage will not be covered under warranty.

## PRESSURE WASHER TERMINOLOGY

**PSI:** Pounds per Square Inch. The unit of measure for water pressure. Also used for air pressure, hydraulic pressure, etc. Operating at pressures exceeding the maximum rating could result in damage to the unit and/or severe personal injury.

**GPM:** Gallons per Minute. The unit of measure for the flow rate of water.

**CU:** Cleaning Units. GPM multiplied by PSI equals CU.

**Pressure Wand Assembly:** This refers to the gun, wand and nozzle.

**Pump:** The pump moves the water through the system and delivers it to the pressure wand assembly. The nozzle creates the pressure.

**Bypass Mode:** Allows water to re-circulate within the pump when the gun trigger is not pulled. This feature allows the operator to release the trigger gun and reposition themselves without having to turn the engine off in between cleaning actions.

**NOTICE:** Allowing the unit to run for more than two minutes without the gun trigger being pulled could cause overheating and damage to the pump. Do not let the pressure washer run for more than two minutes in Bypass Mode. Turn off the engine and relieve the pressure in the gun during these extended situations.

**Thermal Relief Valve:** When the temperature inside the pump rises too high, this valve will open and release a gush of water in an effort to lower the temperature inside the pump. The valve will then close.

**Pressure Relief Valve:** The water heater coils are designed to operate safely at normal working pressure. The safety pressure relief valve prevents over pressurization of the high pressure system. Do not modify the pressure relief valve in anyway.

**High Pressure Pump Oil:** The preferred oil is SIMPSON® Premium Pump Crankcase Oil. If this oil is not available, an SAE 15W-40 oil may be used. Change the pump oil after the first 50 hours of operation and every 100 hours thereafter, or every 3 months.

**Gasoline Engine Oil:** Check engine oil level before each use. Refer to the **Engine Owner's Manual** for correct procedure.

**12V DC Battery:** The 12V DC battery operates the engine's electrical start system, after the engine is started the system will charge the battery and operate the burner. The 12V battery will need to be replaced regularly to ensure consistent performance. Recommended battery size: Group 24 battery

**Burner Assembly:** A device used to change fuel to heat energy. It is used to heat the water in the coil assembly and is designed to use a NO. #2 diesel fuel.

**BTU (British Thermal Unit):** The amount of time it takes to raise the temperature of one pound of water by one degree Fahrenheit.

**Back Flow Preventer:** Prevents backflow into a potable water system.

***WARNING: To reduce the possibility of contamination always protect against backflow when connected to a potable water system***

**Pressure Switch:** A switch which uses a pressure activated plunger to activate a microswitch, used to control the fuel solenoid in the burner system.

**Flow Switch:** A switch which responds to changes in water flow, water flow moves a magnet which activates a reed or microswitch to control voltage to the fuel solenoid in the burner system.

**Chemical Injection System:** Mixes cleaners or cleaning solvents with the water to improve cleaning effectiveness.

**High Pressure Hose:** Only use a wire braid hose rated for the output pressure and temperature of the high pressure pump. See **Specification Insert** for the maximum temperature. Additional hose lengths can be added with quick twist couplers with a minimal loss in pressure of about .5 PSI per foot. Always inspect hoses for wear and replace if necessary. Avoid kinking or running over the hose to extend the hose life.

**Hour meter:** The analog hour meter operates whenever the engine is running and keeps track of how many hours the unit has been used.

**Water Supply:** The minimum requirements for a water supply are 20 psi and 5 **Water Supply:** The minimum requirements for a water supply are 20 psi at twice the stated water volume for the machine. If your water source is a well, the garden hose length can only be 30 ft. (9 m) maximum.

## OPERATION

### PRESSURE WASHER OPERATING FEATURES

**IMPORTANT:** Become familiar with these features before operating this pressure washer.

#### PRESSURE ADJUSTMENTS

The pressure setting is preset at the factory to achieve optimum pressure and cleaning. If you need to lower the pressure, it can be accomplished by these methods.

**Back away from the surface to be cleaned.** The further away you are, the less the pressure will be on the surface to be cleaned.

#### HOW TO USE SPRAY WAND

The nozzles for the spray wand are stored in the nozzle holder on the panel assembly. Colors on the panel identify nozzle location and spray pattern. Refer to the nozzle chart below to choose the correct nozzle for the job to be performed.

#### CHANGING NOZZLES ON SPRAY WAND (FIG. 3)



**⚠ DANGER:** Risk of fluid injection. Do not direct discharge stream toward persons, unprotected skin, eyes or any pets or animals. Serious injury will occur.

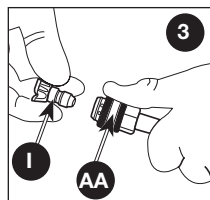

**⚠ WARNING:** Flying objects could cause risk of serious injury. Do not attempt to change nozzles while pressure washer is running. Turn engine off before changing nozzles.

1. Pull quick-connect coupler (AA) back and insert nozzle (I).
2. Release quick-connect coupler and twist nozzle to make sure it is secure in coupler.

**⚠ WARNING:** Flying object could cause risk of serious injury. Ensure nozzle is completely inserted in quick-connect socket and quick-connect collar is fully engaged (forward) before squeezing gun trigger.



NOZZLE COLOR	SPRAY PATTERN	USES	SURFACES*
Red	 0°	powerful pinpoint for spot cleaning of hard, unpainted surfaces or for high reach areas	unpainted metal or concrete; DO NOT use on wood
Yellow	 15°	intense cleaning of unpainted hard surfaces	grills, driveways, concrete or brick walkways, unpainted brick or stucco
Green	 25°	standard cleaning nozzle for most applications	yard tools, sidewalks, lawn furniture, unpainted siding, stucco, gutters and eaves, concrete, brick surfaces

NOZZLE COLOR	SPRAY PATTERN	USES	SURFACES*
White	40° 	cleaning of painted or delicate surfaces	auto/RV, marine, wood, painted brick and stucco, vinyl, painted siding
Black	low pressure 	applies cleaning solutions	Low pressure spray is safe on all surfaces. Always verify compatibility of cleaning solution prior to use.

**\*NOTICE:** The high pressure spray from your pressure washer is capable of causing damage to surfaces such as wood, glass, automobile paint, auto striping and trim, and delicate objects such as flowers and shrubs. Before spraying, check the item to be cleaned to assure yourself that it is strong enough to resist damage from the force of the spray.

### HOW TO APPLY CHEMICALS/CLEANING SOLVENTS (FIG. 4)

Applying chemicals or cleaning solvents is a low pressure operation. **NOTE:** Use only soaps and chemicals designed for pressure washer use. **Do not use bleach.**

#### To Apply Chemicals:

1. Ensure chemical siphon hose (M, Figure 4) is attached to barbed fitting location near high pressure hose connection of pump as shown.
2. Place the end of chemical siphon hose with filter on it into container holding chemical/cleaning solution.
3. Install low pressure (black) nozzle into quick connect fitting of spray wand, see **How To Use Spray Wand** paragraph in this section.
4. After use of chemicals, place chemical siphon hose into container of clean water and draw clean water through chemical injection system to rinse system thoroughly. If chemicals remain in the pump, it could be damaged. Pumps damaged due to chemical residue will not be covered under warranty.

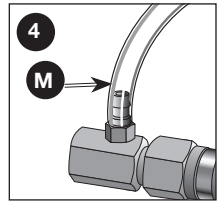

### STARTING

**⚠ WARNING:** Do not operate this unit until you read this instruction manual and the engine instruction manual for safety, operation and maintenance instructions.

**⚠ DANGER:** Risk of fluid injection and laceration. When using the high pressure setting, **DO NOT** allow the high pressure spray to come in contact with unprotected skin, eyes, or with any pets or animals. Serious injury will occur.

- Your washer operates at fluid pressures and velocities high enough to penetrate human and animal flesh, which could result in amputation or other serious injury. Leaks caused by loose fittings or worn or damaged hoses can result in injection injuries. **DO NOT TREAT FLUID INJECTION AS A SIMPLE CUT!** See a physician immediately!

**⚠ DANGER: Carbon Monoxide.** Using an engine indoors can kill you in minutes. Engine exhaust contains high levels of carbon monoxide (CO), a poisonous gas you cannot see or smell. You may be breathing CO even if you do not smell engine exhaust.

- Breathing exhaust fumes will cause serious injury or death! Engine exhaust contains carbon monoxide, an odorless and deadly gas.
- Operate pressure washer in a well-ventilated area. Avoid enclosed areas such as garages, basements, etc.
- Never operate unit in or near a location occupied by humans or animals.

**⚠ WARNING: Risk of Fire, Asphyxiation and Burn.** Never fill fuel tank when engine is running or hot. Do not smoke when filling fuel tank.

- Never fill fuel tank completely. Fill tank to 1/2" (12.7 mm) below bottom of filler neck to provide space for fuel expansion. Wipe any fuel spillage from engine and equipment before starting engine.
- DO NOT let hoses come in contact with very hot engine muffler during or immediately after use of your pressure washer. Damage to hoses from contact with hot engine surfaces will NOT be covered by warranty.

**NOTICE:** Risk of property damage. Never pull water supply hose to move pressure washer. This could damage hose and/or pump inlet.

- DO NOT use hot water, use cold water only.
- Never turn water supply off while pressure washer engine is running or damage to pump will result.
- DO NOT stop spraying water for more than two minutes at a time. Pump operates in bypass mode when spray gun trigger is not pressed. If pump is left in bypass mode for more than two minutes internal components of the pump can be damaged.

If you do not understand these precautions, please contact our customer service department at 1-844-375-7577.

**Before Each Start Up (FIG. 1, 5, 6)**

1. In a well-ventilated outdoor area, add fresh, high-quality, unleaded gasoline with a pump octane rating of 86 or higher. Do not overfill. Wipe up spilled fuel before starting the engine. Refer to **Engine Owner's Manual** for correct procedure.

— Ethanol Percentage — **NOTICE:** Use of fuels with greater than 10% ethanol are not approved for use in this product per EPA regulations and will damage the unit and void the warranty.



2. Check engine oil level. Refer to the **Engine Owner's Manual** for correct procedure.
3. Check pump oil level. The oil level should come to the dot in the middle of the sight glass (S, Fig 2).
4. In a well-ventilated outdoor area, add fresh, high-quality #2 diesel fuel to the burner fuel tank fill.
5. Visually inspect all electrical components, hoses, nozzles and guns to assure they are in good condition. If replacements are necessary they must be rated to withstand the machines operating pressure and temperatures. See **Specification Insert**.
6. Verify the filter screen (BB) is in water inlet on the machine. NOTE: Convex side faces out. Connect the cold water source to pump inlet (L). NOTE: Failure to use machine without inlet screen filter installed may void warranty.

**⚠WARNING:** To reduce the possibility of contamination always protect against backflow when connected to a potable water system.

7. Connect the water hose to the cold water source. Turn the water source on to remove all air from the hose. When a steady stream of water is present, turn the water source off. NOTE: Use a 5/8" (15.9 mm) or 3/4" (19.0 mm) good quality water hose of minimal length. NOTE: Water source pressure must be 20–60 psi to ensure proper operation.
8. Connect high pressure spray wand (N) to gun (P). Tighten securely. Refer to **Spray Wand Nozzles** to select the correct quick connect nozzle for the task being performed.
9. Attach high pressure hose (O) to high pressure spray gun (P). Connect the other end of the high-pressure hose to high-pressure hot water outlet on the machine.
10. If applying a chemical or cleaning solution, refer to **Chemicals and Cleaning Solvents**.
11. Make sure ALL controls are in the OFF position.
12. Start engine. Refer to the engine instruction manual for correct procedure. IMPORTANT: Prior to starting, refer to your engine manual for proper starting procedure.

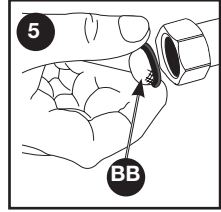

**⚠WARNING:** Risk of unsafe operation. If engine does not start after two pulls, squeeze trigger of gun to relieve pump pressure. Pull starter cord slowly until resis-tance is felt. Then pull cord rapidly to avoid kickback and prevent hand or arm injury.

**NOTE:** If the oil level in the engine is low, the engine will not start. If the engine does not start, check the oil level and add oil as needed.

13. If hot water cleaning is desired, release the trigger on the gun and place the burner On/Off switch (G) in the ON position.

**⚠WARNING:** Risk of burns. The surfaces around the burner exhaust and the discharged exhaust are very hot. Keep away from this area. DO NOT allow hoses to come in contact with the very hot burner exhaust area.

**⚠WARNING:** Burner will shut off when the trigger is released. DO NOT use the pressure washer if the burner fails to shut off when the trigger is released.

14. Depress trigger on gun to start water flow and the burner.
15. Release trigger to stop water flow and turn the burner off.
16. Adjust the pressure if needed. Refer to Pressure Adjustments paragraph for the correct procedures.

**⚠WARNING:** Risk of unsafe operation. Stand on a stable surface and grip gun/wand firmly with both hands. Expect the gun to kickback when triggered.

**NOTICE:** Allowing the unit to run for more than two minutes without the gun trigger being pulled could cause overheating and damage to the pump. Do not let the pressure washer run for more than two minutes in Bypass Mode. Turn off the engine and relieve the pressure in the gun during these extended situations.

**⚠ DANGER:** Risk of injury from spray. Engage the trigger lock (CC) when gun is not in use to prevent accidental spraying.

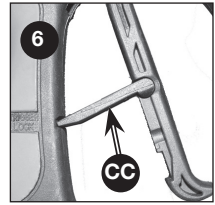

### SHUTTING DOWN (FIG. 1)

1. Place the burner on/off switch (G) in the OFF position.
2. Depress trigger on gun and allow water to run until the spray wand is no longer hot to the touch.
3. If chemicals were applied, place the chemical siphon hose into a container of clean water and draw clean water through chemical injection system to rinse system thoroughly.

**NOTICE:** Risk of property damage. Failure to rinse the chemical system can cause damage to the high-pressure pump or the high-pressure water system.

4. Turn engine off. Refer to the **engine instruction manual** for correct procedure.

**NOTICE:** Risk of property damage. NEVER turn water supply off while pressure washer engine is running or damage to pump will result.

5. Turn water source off.
6. Pull trigger on spray gun to relieve any water pressure in hose or spray gun.
7. Refer to **Storage** for proper storage procedures.

## MAINTENANCE

Your pressure washer has been produced with the highest quality materials and craftsmanship, as the owner you have certain responsibilities for the correct care of the equipment. Attention to regular preventative maintenance procedures will assist in preserving the performance of your equipment.

Contact your local service provider for maintenance. A small investment in preventative maintenance will add many hours to the life of your pressure washer. Perform maintenance more often under severe conditions. Do not spray high-pressure water onto the machine. Not all maintenance items apply to all machines.

### MAINTENANCE SCHEDULE\*\*

Engine Oil	Inspect	Daily
	Change	After first 10 hours then every 50 hours especially in high ambient temperatures
	Filter	Every 100 hours
Air Cleaner	Inspect	Every 25 hours
	Clean	Every 3 months
Diesel Engine Coolant	Check daily	(maximum 50% antifreeze)
Battery Level	Check monthly	12V DC Burner Systems: Replace battery every 2 years
Engine Fuel Filter	500 hours or 6 months	
Spark Plug Maintenance	500 hours or 6 months	
Clean Fuel Tank(s)	Annually	
Replace Fuel Lines	Annually	
Pump Oil	Inspect	Daily
	Change	After first 25 hours, then every 3 months or 150 hours
		Axial pumps come filled with synthetic oil, which does not require changing
Replace Burner Fuel Filter	Every 6 months	(More often if fuel quality is poor)
Remove Burner Soot	Annually	
Burner Adjustment/Cleaning	Annually	
De-scale Coil	Annually	(More often if required)



Replace Spray Nozzle	Every 6 months	
Replace Quick Connects	Annually (More often if required)	
Clean Water Screen/Filter	Weekly	
Clean Float/Supply Tank	Every 6 months	
Replace HP Hose	Annually (More often if required)	
Belts	Tighten	Every 6 months
	Inspect/Replace	Annually
Trailer Tires/Bearings	Monthly (Check tires for condition, tighten lug nuts, grease & check bearings)	

### **CALIFORNIA PROP 65 WARNING**

Detectable amounts of chemicals known to the State of California to cause cancer, birth defects or other reproductive harm may be found in pressure washing equipment and accessories. California Health and Safety Code 25249.5

## **STORAGE**

### **ENGINE**

Consult the **Engine Owner's Manual** for manufacturer's recommendations for storage.

### **PRESSURE WASHER**

1. Drain all water from high-pressure hose.
2. With nozzle pointed down and the spray gun and wand in a vertical position, squeeze trigger to drain all water from spray gun and wand.
3. Store chemical siphon hose so it is protected from damage.

**⚠ CAUTION:** *Risk of personal injury. Avoid placing hands between handle and frame when assembling to prevent pinching.*

**NOTICE:** *Risk of property damage. Always store and transport unit in an upright position.*

## **ACCESSORIES**

**⚠ DANGER:** *Risk of fluid injection. When using replacement spray wands or guns with this pressure washer, DO NOT use a spray wand and/or spray gun/wand combination that is shorter in length than what was provided with this pressure washer as measured from the nozzle end of the wand to the gun trigger.*

**NOTICE:** *The use of any other accessory not recommended for use with this tool could be hazardous. Use only accessories rated equal to or greater than the rating of the pressure washer.*

## SPECIFICATIONS

---

---

<b>SERIES NUMBER</b>	65132 (electric start) & 65133
<b>MAX PRESSURE</b>	4000 PSI
<b>MAX FLOW</b>	4.0 GPM
<b>ENGINE</b>	Simpson GB420 electric start or Honda GX390
<b>ENGINE WARRANTY</b>	See Engine Owner's Manual
<b>CONTROLS / SWITCHES</b>	Backlit Rocker, Flow Switch, Key Switch, Hour Meter
<b>PUMP</b>	AAA C4X or GP EZ4040G
<b>PUMP WARRANTY</b>	See Limited Warranty
<b>BURNER</b>	12VDC WAYNE MSR OIL FIRED
<b>POWER DRIVE</b>	Direct
<b>WATER SUPPLY</b>	Garden Hose
<b>DETERGENT</b>	Soap Injector
<b>PRESSURE HOSE</b>	3/8"x50'x4500PSI Gray PU HW SWV/Rigid
<b>NOZZLE</b>	4.5 - 15° 25° 40° Soap
<b>ELECTRICAL ENCLOSURE</b>	Flush mounted NEMA 4X Box
<b>ELECTRICAL</b>	12-Volt DC

## SERVICE INFORMATION

---

---

**Do not return this product to your retailer.** Please contact our customer service department at 1-844-375-7577.

## TROUBLESHOOTING GUIDE

*Probable causes are listed with most likely cause first.  
ALL Repairs should be made by qualified technicians only.*

<b>TROUBLESHOOTING GASOLINE/DIESEL ENGINES</b>		
<b>Problem</b>	<b>Probable Cause</b>	<b>Remedy</b>
<b>Engine will not start or crank over.</b>	Battery dead Where applicable	Charge or replace battery, add electrolyte if battery is new
	Dirty Battery Contacts	Clean connections
	Battery cables disconnected	Connect or replace damaged cables.
	Engine, pump, or gearbox is seized.	Identify, Replace or repair seized part.
	Key switch, solenoid or starter on engine defective.	Repair or replace faulty component.
	Pump is seized	Replace pump or bearing.
<b>Engine will not start but will crank over</b>	Engine power switch is off or defective.	Check engine power switch.
	Low oil shut down is activated.	Add oil to engine, check more frequently.
	Low on fuel.	Fill with the appropriate fuel, bleed injector pump on diesel engines.
	Fuel filter is clogged.	Replace or clean fuel filter, bleed injector pump on diesel engines.
	Engine flooded or starved.	Choke only as required (not applicable to diesels).
	Air Filter is dirty	Clean or replace air filter
<b>Engine bogs down under load, whenever spray gun is triggered.</b>	Old or dirty fuel	Drain and replace with new fuel
	Engine needs to be repaired or replaced.	See engine manual or engine dealer.
	Operating in high elevation.	Lower the pressure on the unit and check for correct engine speed (RPM).
	Incorrect nozzle in lance	Replace with correct nozzle size
	Unloader valve improperly adjusted.	Adjust unloader valve
	Carbon deposits on cylinder head.	Remove head and clean off deposits.

<b>TROUBLESHOOTING PRESSURE ISSUES</b>		
<b>Problem</b>	<b>Probable Cause</b>	<b>Remedy</b>
<b>Trigger gun leaks or will not shut off.</b>	Debris in gun valve assembly.	Clean valve assembly or replace gun.
<b>Pump runs but there is no spray pressure.</b>	Water turned off.	Turn water on.
	Nozzle is plugged.	Clean or replace with proper size.
	Inlet chemical injection valve is open, without the end of the pickup tube inserted into detergent. (upstream injection systems only)	Close soap valve or submerge detergent pickup tube into solution.
	Coil on hot water machines is obstructed.	Clean obstruction or scale deposits from coil with coil cleaner.
	Pump dry, needs to be primed.	Crack open fitting on the high pressure outlet of the pump until water flows out.

<b>TROUBLESHOOTING PRESSURE ISSUES</b>		
<b>Problem</b>	<b>Probable Cause</b>	<b>Remedy</b>
<b>Pump runs but has low spray pressure.</b>	Nozzle not installed	Install proper sized nozzle.
	Dual wand valve is open.	Dual wand valve must be closed and high pressure nozzle installed.
	Leaky discharge hose or quick coupler.	Replace hose, quick coupler, or O-ring in the quick coupler.
	Inlet strainer clogged.	Clean and check more frequently.
	Worn or wrong size nozzle.	Replace nozzle of proper size.
	Belt slippage	Tighten or replace with correct belt.
	Unloader valve worn or improperly adjusted.	Install pressure gauge on pump head to adjust pressure. Check valve seat on Unloader.
Air leak in inlet plumbing.	Reseal fittings and inspect inlet hoses for air leaks.	
<b>Pump runs but there is erratic, fluctuating pressure.</b>	Inadequate incoming water supply.	Increase water supply flow.
	Stuck inlet or discharge valves.	Clean out or replace worn valves
	Restricted inlet or air entering the inlet plumbing on the pump.	Check fittings and hose for air tight seal, clean inlet strainer screen.
	Leaking H.P. seals.	Replace seals.
	Leaking L.P. seals.	Pressure feed the pump and replace LP seals if water leaks from the pump head.
<b>Excessive crankshaft play or loud, knocking noise in pump.</b>	Broken or worn bearing or connecting rod in crankcase.	Replace pump or bearing.
<b>Oil leaking from pump.</b>	Loose drain plug or damaged seal.	Locate point of oil leakage and replace damaged O-ring or seal.
	Leaking crankshaft oil seal	Replace seal
	Leaking Oil Sight Glass seal	Replace seal
	Leaking Piston Oil Seal	Replace seals. Install correct amount of oil in pump
<b>Inlet injection will not siphon chemical.</b>	Check valve in strainer clogged.	Clean or replace. Rinse after each use.
	Chemical valve not open or clogged.	Open chemical valve or clean.
	Strainer not submerged in solution.	Submerge strainer and replenish chemical.
	Detergent hose cut or kinked	Inspect hose, replace as necessary.
<b>Water is emitted from the chemical pickup tube</b>	Check valve malfunctioning.	Repair or replace check valve.

<b>TROUBLESHOOTING PRESSURE ISSUES</b>		
<b>Problem</b>	<b>Probable Cause</b>	<b>Remedy</b>
<b>Downstream injector will not siphon chemical.</b>	Adjustable knob on injector is closed (Where applicable)	Open by turning counter clockwise.
	Unit not in low pressure mode.	Open dual wand or install low pressure (BLACK) tip.
	Detergent hose cut or kinked.	Inspect hose, replace as required.
	Chemical Strainer plugged or not submerged.	Check screen on strainer pickup tube.
	Internal injector parts corroded or stuck.	Disassemble, clean or replace.
	Outlet water temperature too high.	Use with cold water (150° Maximum)
<b>Pressure relief Valve expelling water</b>	Unloader failure / coil overheating / Excessive pressure	Turn machine off wait a few minutes and restart. If problem continues take to an authorized repair center for complete system check.

<b>TROUBLESHOOTING OIL FIRED BURNER SYSTEMS</b>		
<b>Problem</b>	<b>Probable Cause</b>	<b>Remedy</b>
<b>Burner will not fire.</b> <b>WARNING:</b> <b>High voltage on igniter can cause electrical shock. Disconnect power before servicing.</b>	Burner switch not on.	Turn switch on; Thermostat on if equipped.
	Diesel fuel level low.	Fill burner tank with #2 diesel or other approved fuel.
	Trigger on spray gun not pulled.	Squeeze trigger to fire burner.
	Fuel filter plugged.	Clean and / or tighten fuel filter. (Check fuel pressure)
	Spray nozzle plugged.	Clean spray nozzle.
	<b>Burner will not fire.</b> <b>WARNING:</b> <b>High voltage on igniter can cause electrical shock. Disconnect power before servicing.</b>	Overload on burner motor tripped.
Nozzle not in wand.		Install nozzle in wand.
Low water pump pressure.		See pumping systems trouble shooting.
Fuel pump or nozzle stopped.		Check fuel pressure, filter, fuel lines. Replace fuel pump and/or nozzle.
Vacuum, Flow, Pressure or Temperature switch faulty.		Check electrical continuity with pump spraying and burner on.
Fuel solenoid valve faulty.		Replace fuel valve if it does not open when power is applied.
Low generator voltage output.		Adjust generator RPM for proper voltage under full load conditions.
Burner relay faulty (12-V Burner only)		Replace burner relay.
<b>Burner will not fire, and diesel fumes are emitted from the exhaust port.</b> <b>WARNING:</b> <b>Replace insulation. Unburned fuel can saturate it and cause a fire.</b>	Fuel to air ratio out of adjustment.	Set air band and fuel pressure to specs.
	Fuel nozzle partially clogged.	Replace nozzle of proper size.
	Ignition transformer not providing spark to fuel.	Replace ignition transformer, clean and adjust electrodes.
	Fuel to air ratio out of adjustment.	Set air band and fuel pressure to specs.

<b>TROUBLESHOOTING OIL FIRED BURNER SYSTEMS</b>		
<b>Problem</b>	<b>Probable Cause</b>	<b>Remedy</b>
<b>Burner fires and smokes.</b>	Excessive soot on coils.	Clean soot off to improve air flow.
	Improper voltage at burner	Adjust RPM of generator (if equipped)
	Burner input too high for conditions.	Decrease fuel pump pressure and/or fuel nozzle size.
<b>Discharge water temperature exceeds recommended operating temperature.</b>	Water flow restricted.	Clean or replace nozzle of proper size. Descale coil and clear obstructions.
	High temperature limit switch faulty or set too high.	Replace or reset temperature limit switch.
	Faulty Flow, Pressure or Vacuum switch.	Replace switch.
<b>Burner continues to fire even when trigger on spray gun is released</b>	Faulty fuel solenoid	Replace solenoid
	Burner input too low for conditions	Increase fuel pump pressure and/or fuel nozzle size.
<b>Discharge water temperature not reaching maximum operating temperature.</b>	Battery voltage Low.	Have battery checked and load test, charge if low and replace if necessary. Allow water to cool 2 min. before shutting off engine.
<b>Battery keeps losing voltage. (For 12 volt burner systems)</b>	Engine RPM too low.	Engine RPM should be 3600 RPM w/no load.
	Engine charging system faulty.	Check engine charging system – Must have 16 Amp output minimum
	Electrodes misadjusted	Adjust electrodes to maximum 1/8" gap.
	Fuel pump pressure too high.	Fuel pump pressure should be approximately 100 to 140 PSI.
	Air band open too far.	Adjust for proper burn.
	Burner amp draw too high.	Check amp draw of burner motor – should be 13 amp or less. Check amp draw of transformer should be 4.2 or less.

## LIMITED WARRANTY

All FNA GROUP® pressure washers are warranted by the FNA GROUP® to the original purchaser to be free from defects in materials and workmanship under normal use, for the periods specified below. This Limited Warranty is subject to the exclusions shown below, applies to the original components only and, is calculated from the date of the original purchase. Any parts replaced under this warranty will assume the remainder of the part's original warranty period. These warranties pass through to the original purchaser only and are nontransferable. To find the nearest Authorized Service Center (ASC) contact the customer service group: for Cold Water service (877-362-4271) and for Hot Water service (844-375-7577). The customer is responsible to maintain and provide a copy of the purchase receipt to the Authorized Service Center at the time of repair to prove warranty status.

Component	Warranty Period	Exclusions or Comments
Industrial Frame/ Handle Assemblies (Welded Steel or Aluminum) Powershot, WaterBlaster, Water Shotgun, Delco® Equipment	10 year(s) Parts, 1 year labor	Rust, chemical damage, misuse/abuse
AAA® Triplex Pumps	5 year(s) Parts, 1 year labor	Freezing, Water Quality, Chemical damage, over pressurization, Low Water supply
GENERAL PUMP® Belt/Direct Drive Pumps	5 year(s) Parts, 1 year labor	Pumps are evaluated by GENERAL PUMP®
CAT® Belt Drive Pumps	5 year(s) Parts, 1 year labor	Pumps are evaluated by CAT® Pump
COMET PUMP® Belt/Direct Drive Pumps	5 year(s) Parts, 1 year labor	Pumps are evaluated by COMET PUMP®
Coils, Coil Tanks, Fuel/Float Tanks, Belt Guards	5 year(s) Parts, 1 year labor	Freezing, Water Quality, Chemical damage, over pressurization
Honda Engines	See Honda Engine Manual	See Engine Manual
Simpson® Engines	2 year(s) Parts, 1 year labor	Incorrect or contaminated fuel, Low oil levels
OEM® Axial Pumps	1 year Parts, 1 year labor	Freezing, Water Quality, Chemical damage, over pressurization, Low water supply
Electric Pump/motor Assemblies	1 year Parts, 1 year labor	Freezing, Water Quality, Chemical damage, over pressurization, Low water supply
Delco Engines, Simpson Generators, Burner Assembly Components	1 year Parts, 1 year labor	Freezing, Fuel Quality, damage due to over pressurization, incorrect voltage
Consumer Frame/handle components (MegaShot)	1 year Parts, 1 year labor	Rust, chemical damage, misuse/abuse
Electrical Components, Switches, Contactors, Overload relays, Transformers, PC Boards, Control Modules	90 day Parts, 90 day labor	Rust, chemical damage, misuse/abuse, Freezing, Fuel Quality, damage due to over pressurization, incorrect voltage
Accessory Items: Nozzles, hoses, trigger guns, wands/lances, injectors, unloader valves, hose reels, foamers, GFC's, relief valves, filters, wheels, tires, surface cleaners, soap tanks, plastic bonnet assemblies	90 day Parts, 90 day labor	Rust, chemical damage, misuse/abuse, Freezing, Fuel Quality, damage due to over pressurization, incorrect voltage

### WARRANTY PROVIDED BY OTHER MANUFACTURERS:

Electric Motors and Gasoline or Diesel engines, which are warranted by their respective manufacturers, are serviced through these manufacturers' local authorized service centers. The FNA GROUP® is not authorized and has no responsibility to provide warranty service for such components.

**This warranty does not cover the following items:**

1. Normal wear items, such as, seals, O-rings, packing's, pistons, pump valve assemblies, strainers, belts, brushes, fuses, filters, fans or gaskets.
2. Damage or malfunctions resulting from accidents, abuse, modifications, alterations, incorrect installation, improper servicing, failure to follow manufacturer's maintenance instructions, or use of the equipment beyond its stated usage specifications as contained in the operator's manual.
3. Damage due to freezing, chemical deterioration, scale build up, rust, corrosion, water quality or thermal expansion.
4. Damage to components from fluctuations in electrical or water supply.
5. Normal maintenance service, including adjustments, fuel system cleaning, and clearing of obstructions.
6. Travel expenses or shipping costs of machines or components for the purposes of repair or replacement of equipment.
7. The Manufacturer's warranty obligation is limited to repair or replacement of defective components as provided herein and the Manufacturer shall not be liable for any further loss, damages, or expenses – including damages from shipping, accident, abuse, acts of God, misuse, water quality or neglect. Neither is damage from repairs using non-OEM parts or alterations performed by non-factory authorized personnel nor Failure to install and operate equipment according to the guidelines put forth in the instruction manual shall void warranty.

### LIMITATION OF LIABILITY

The FNA GROUP's liability for special, incidental, or consequential damages is expressly disclaimed. In no event shall The FNA GROUP's liability exceed the purchase price of the product in question. The FNA GROUP makes every effort to ensure that all illustrations and specifications are correct, however, these do not imply a warranty that the product is merchantable or fit for a particular purpose, or that the product will actually conform to the illustrations and specifications. Our obligation under this warranty is expressly limited at our option to the replacement or repair at a service facility or factory designated by us, of such part or parts as inspection shall disclose to have been defective. **THE WARRANTY CONTAINED HEREIN IS IN LIEU OF ALL OTHER WARRANTIES, EXPRESS OR IMPLIED, INCLUDING ANY IMPLIED WARRANTY OF MERCHANTABILITY OR FITNESS FOR A PARTICULAR PURPOSE** are expressly limited to the duration of this written warranty. The FNA GROUP® does not authorize any other party, to make any representation or promise on behalf of The FNA GROUP®, or to modify the terms, conditions, or limitations in any way. It is the buyer's responsibility to ensure that the installation and use of products conforms to local codes. While FNA attempts to assure that its products meet national codes; it cannot be responsible for how the customer chooses to use or install the product. Some states do not allow limitations on how long an implied warranty lasts or the exclusion or limitation of incidental or consequential damages, so the above limitation or exclusion may not apply.

Corporate Office  
7152 99th Ave  
Pleasant Prairie WI, 53158  
(847) 348-1500

FNA Group  
www.fna-group.com

Manufacturing Operations  
1265 Industrial Drive  
Decatur, AR 72722

Copyright. All Rights Reserved

Assembled in U.S.A with domestic and foreign components