



**IF YOU EXPERIENCE ANY ISSUE WITH YOUR PRESSURE WASHER,
WE ARE HERE TO HELP YOU.**

Contact FNA Group at cservice@fna-group.com or 1-877-362-4271.

SHOULD YOU REQUIRE ASSISTANCE WITH A PART THAT MAY BE BROKEN OR MISSING, OR YOU ARE HAVING DIFFICULTY WITH ASSEMBLY OR STARTING, PLEASE CONTACT US. YOUR COMPLETE SATISFACTION IS OUR PRIMARY OBJECTIVE.

Notes:

1. This quick start guide is not a replacement for the owner's manual. Be sure to read the owners manual before operating the machine for the first time.
2. Read all the information in the safety section of this document and all related user manuals before operating the machine.
3. Perform the procedures outlined in this quick start guide before operating the machine.

Contact Us:

If you have any questions regarding the unpacking, assembly, or use of your pressure washer, please have your model number and serial number ready, then contact customer support at **1-877-362-4271** or email cservice@fna-group.com.

Disclaimers:

- All information in this guide was based on the latest product information available at the time of its printing.
- This guide may cover more than one machine. The drawings in this guide should be used for reference only. There may be differences between your product and the pictures, drawings, and / or diagrams used in this guide.
- In a continued commitment to improve quality, The manufacturer reserves the right to update, change, and / or improve the product(s) covered in this guide at any time, without notice, and without incurring any obligation. Therefore, the product(s) this guide covers may differ slightly those pictured.

Safety: **NOTE:** Be sure to read understand the safety information listed below. Each box contains one of three words: WARNING, CAUTION, or NOTICE each of these words indicates a different level of hazard severity and is followed by information about specific hazards, the consequences of the hazards, and instructions on how to avoid the hazards. Failure to heed these symbols and the information provided with them could result in property damage, injury, and/or death.

⚠ WARNING:

Indicates a potentially hazardous situation which, if not avoided, could result in property damage, serious injury, and/ or death.

⚠ CAUTION:

Indicates a hazardous situation, which if not avoided, could result in property damage and/or minor to moderate injury.

NOTICE

Indicates information considered important but not directly hazard related.

⚠ WARNING: OPERATION CHECKLIST

Attempting to start the engine incorrectly or using the pressure washer incorrectly can result in engine and/ or pressure washer damage, and may cause serious injury or death. To avoid these hazards, be sure to read, understand, and follow the steps outlined in the OPERATING CHECKLIST section of the owner's manual before starting the engine, and follow all the guidelines for proper use of the pressure washer.

⚠ WARNING: MOVING PARTS

This product has many parts that move at high speeds. Moving parts can cause crushing injuries, broken bones, severe lacerations, and/or traumatic amputations. To prevent injury, never place fingers, hands, feet, or other body parts near running engine. Never operate product with covers, shrouds, or other guards removed. Do not wear loose-fitting clothing, dangling drawstrings, or any other hanging items that could become entangled in moving parts while operating. Tie up long hair and remove jewelry before operating.

⚠ WARNING: INSPECT

Failure to inspect this product and before use could result in product damage, serious injury, and/or death. To avoid these hazards, inspect the pressure washer before each use. Check for loose or damaged parts, signs of oil or fuel leaks, missing guards, plugged cooling vents, or any other condition that may affect proper operation. Repair or replace all damaged or defective parts and keep all safety guards in place and in proper working order before using the pressure washer.

⚠ WARNING: UNTRAINED OPERATION

Untrained persons, young children, and pets can be seriously injured or killed if allowed to incorrectly operate or play with a running pressure washer. To avoid these hazards, be sure anyone operating the pressure washer receives proper instructions, understands safe operation, and has read the owner's manual before operating this product. Do not let children operate the pressure washer without parental supervision. Keep young children and pets away from the pressure washer while it is running. Always turn off the pressure washer before leaving the area.

⚠ WARNING: REFUELING

Diesel fuel is flammable and diesel vapors are extremely explosive. Fire and explosions can cause severe burns and/or death. Keep diesel fuel away from flames, sparks, and other ignition sources. Refuel outdoors in a well-ventilated area with the engine stopped and cool. Wipe up any spilled fuel and allow engine to dry before starting. Keep a fire extinguisher handy while refueling. Do not operate engine with leaks in the fuel system. Do not store diesel fuel near other flammable materials.

⚠ WARNING: TOXIC FUMES

Engine exhaust contains carbon monoxide, an odorless, colorless, poisonous gas. Running an engine indoors will kill you in minutes. Never use this product inside a house, garage, or any other kind of enclosure even if doors and windows are open. Run engine outside at least 20 feet (6 meters) away from windows, doors, and vents. Carefully consider wind direction and air currents when using this product outside to avoid breathing in engine exhaust. Always use a carbon monoxide detector in any occupied buildings near the running engine.

⚠ WARNING: TRANSPORTATION

Transporting the pressure washer in an enclosed space on a transport vehicle where temperatures can rise may cause fuel to vaporize and leak. Diesel fuel is flammable and diesel vapors are extremely explosive. Fire and explosions can cause severe burns and/or death. To avoid these hazards, secure the pressure washer in a well ventilated area out of direct sunlight and other heat sources and do not transport the pressure washer on rough roads unless the fuel has been drained beforehand.

⚠ WARNING: VOLATILE LIQUIDS

Pressure washing with volatile, flammable, or corrosive liquids could cause pressure washer damage, fire, or explosion resulting in severe injury and/or death. To avoid these hazards, use only approved soaps and chemicals, do not attempt to pressure wash with volatile, flammable, or corrosive liquids, and NEVER use bleach.

⚠ WARNING: INJECTION INJURY

The high pressures created by a pressure washer can cause fluid injection injuries, severe lacerations, amputations, and / or death. To avoid these hazards, always aim the spray gun and lance in a safe direction when using a pressure washer and never attempt to touch a leak in a high-pressure hose or fitting.

⚠ CAUTION: HOT SURFACES

A running engine produces heat. The surfaces of the engine, other related components, and engine exhaust gas get hot enough to cause mild moderate burns or ignite materials on contact. To avoid burns, do not touch engine surfaces or exhaust gases while operating and allow engine to cool completely before moving, touching, or performing any maintenance. To avoid a fire, keep all flammable materials at least five feet away from all sides of the product.

⚠ CAUTION: HOT OIL

Hot oil can cause serious burns. To prevent getting burned when changing or checking the engine oil, use gloves to prevent hot oil from touching skin and change oil when the engine is warm from but not hot.

⚠ CAUTION: FUEL TANK PRESSURE

Diesel vapor can build up inside the fuel tank creating pressure. This pressure may increase when the engine is hot from running. Opening the fuel tank under pressure can cause rapid escape of flammable vapors and possible fuel spills that may ignite from contact with hot engine surfaces resulting in burn hazard. To avoid these hazards, always allow the engine to cool for at least 2 minutes before removing fuel cap and loosen the fuel cap slowly to relieve any pressure in the tank.

⚠ CAUTION: HOT ENGINE COOLANT

Hot engine coolant and steam can cause serious burns. To prevent getting burned by hot engine coolant, never open the engine radiator or overflow bottle when the engine is hot from running and wear gloves when checking or filling coolant to prevent coolant from contacting skin.

NOTICE CHEMICAL CLEANERS

Using chemical cleaners and/or corrosive liquids can damage the pressure washer seals and internal components. Damage caused by chemical cleaners and corrosive liquids is not covered under warranty. To avoid these hazard, only used approved cleaning chemicals, never use bleach, and always run clean water through the pressure washer after using cleaning chemicals.

NOTICE FUEL ADDITIVES

The use of fuel system cleaning additives can damage the engine and fuel systems. Damage caused by the use of fuel system cleaning additives is not covered by warranty. To avoid engine and fuel system damage, do not use any fuel system cleaning additives.

NOTICE LOW OIL SENSOR

The low oil sensor (if equipped) will automatically stop the engine when the oil level falls below the safe limit. To avoid an unexpected shutdown, check the oil level regularly, fill to the upper limit, and always operate engine on a level surface.

NOTICE SPRAY DAMAGE

High-pressure spray can damage plants and other surfaces. To avoid damaging plants, cover them before spraying near them. To avoid damaging surfaces. Refer to the Nozzle Selection table in this manual for correct nozzle and test surfaces before spraying to make sure they are strong enough to withstand high-pressure spray.

NOTICE USE CORRECT ENGINE OIL

Oil is a major factor in the performance and service life of any engine. Using the incorrect oil may damage the engine and void the warranty. To avoid causing engine damage and voiding the warranty, check and change oil as required using the correct engine oil.

NOTICE PUMP DAMAGE

Turning off the water supply to your pump with the engine running will damage the pump. Damage caused by running the pump without water is not covered under warranty. To avoid this hazard always turn off the engine before shutting off the water supply.

NOTICE OLD FUEL

Old Fuel can create deposits that clog fuel systems causing hard starting and poor performance. Damage caused by old fuel is not covered by warranty. To minimize deposits, avoid old fuel related performance issues, and prevent costly repair work, do not use gasoline that is older than 30 days.

NOTICE PUMP FREEZE

Allowing water to freeze inside a pressure washer can damage the hoses and pump. Damage caused by freezing is not covered under warranty. To avoid these hazards, avoid using your pressure washer in freezing temperatures, drain the water from hoses before storing, store your pressure washer in a warm environment, use a pump anti-freeze when storing over the winter, or have a service center winterize your pressure washer.

NOTICE PUMP PURGING

Running a pressure washer pump without water will severely damage the pump seals and other internal components. To avoid this hazard, make sure your water supply is uninterrupted, provides at least 10 GPM at 20 PSI, and always purge the air your pressure washer pump before starting the engine.

NOTICE FILL ENGINE OIL BEFORE USING

The engine is shipped from the factory without oil. Running the engine without oil will result in severe engine damage and void the warranty. To avoid causing engine damage and voiding the warranty, fill the engine with the recommended oil type.

NOTICE CLEANING

Water can damage the pressure washer engine components if allowed to enter through cooling slots or other holes. Damage caused by water intrusion is not covered under warranty. To avoid engine water damage, do not use a pressure washer, garden hose, or any other sources of running water to clean the pressure washer engine, and never submerge the pressure washer engine in any liquids.

NOTICE PUMP DAMAGE

Running the pressure washer for more than two minutes without the spray gun trigger pulled will overheat the pump and possibly cause damage. The thermal relief valve will open and spray water to help cool the pump as it overheats. To avoid overheating the pump, shut off the machine if not being used for longer than two minutes.

NOTICE DO NOT OVERFILL FUEL TANK

Overfilling the fuel tank can result in fuel spills that may ignite from contact with hot engine surfaces resulting in burn hazard. To avoid these hazards, do not fill the fuel tank above the maximum level.

NOTICE DIESEL GEL

Diesel fuel can gel at low temperatures. Damage caused by gelled diesel fuel is not covered under warranty. To avoid these hazards, use a winterized diesel fuel, store the pressure washer and diesel fuel in a warm environment, and keep fuel tanks full.

NOTICE FREEZE DAMAGE

Anytime the pressure washer may endure freezing temperatures, remaining water needs to be drained from the pump, high-pressure hose and spray gun assembly. Drain the hose, spray gun and pump as explained in the pressure washer Use and Care Manual. It is suggested to purge the pump of water by using Simpson® Pump Guard or equivalent pump protectant.

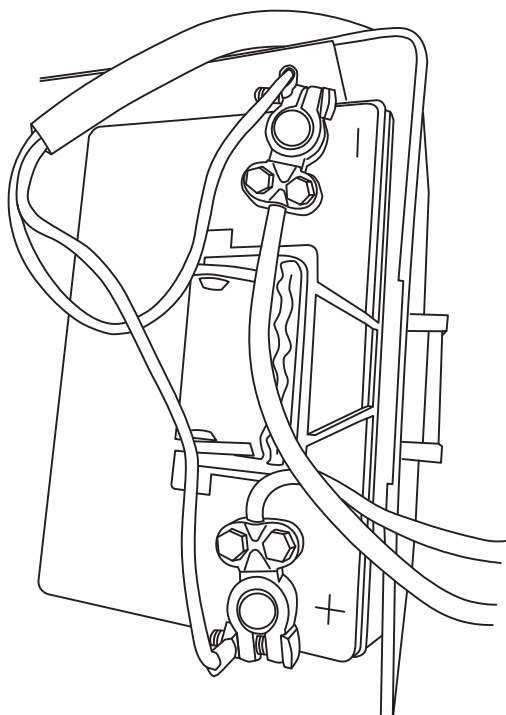
Install Battery:

1. Place Group 34 (min. 665 CCA / 70Ah) automotive battery (not included) into the battery box. Next connect the red and white wires to the positive battery post then connect the black cables to the negative battery post.

2. Install the battery box lid and secure it with the strap and buckle assembly.

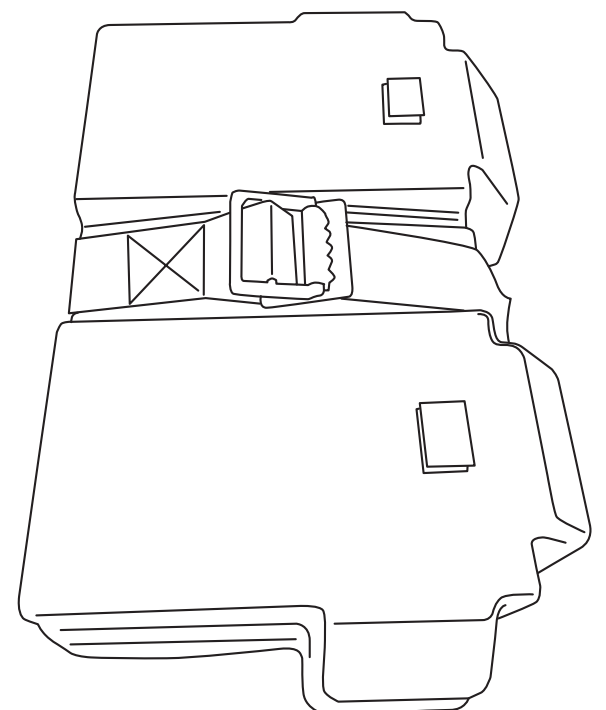

Fill Engine With Oil:

1. Place machine on a level surface then remove the engine oil dipstick.

Engine Oil Dipstick

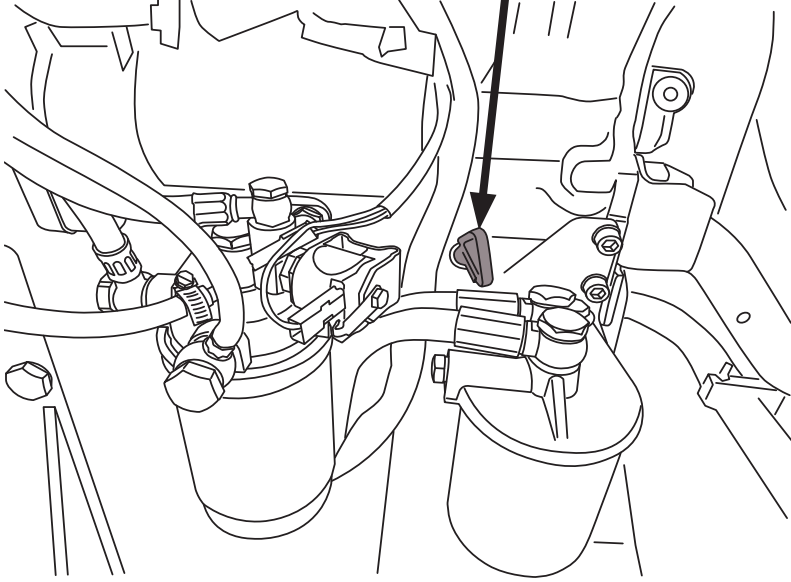

NOTICE

This pressure washer was shipped from the factory without oil in the engine. Running the engine without oil will result in severe engine damage and void the warranty. To avoid causing engine damage and voiding the warranty, fill the engine with the recommended oil type before starting.

2. Fill the engine with the correct oil per the engine owner's manual. The oil level should be towards the high mark on the dipstick. Replace the dipstick when the engine is full.

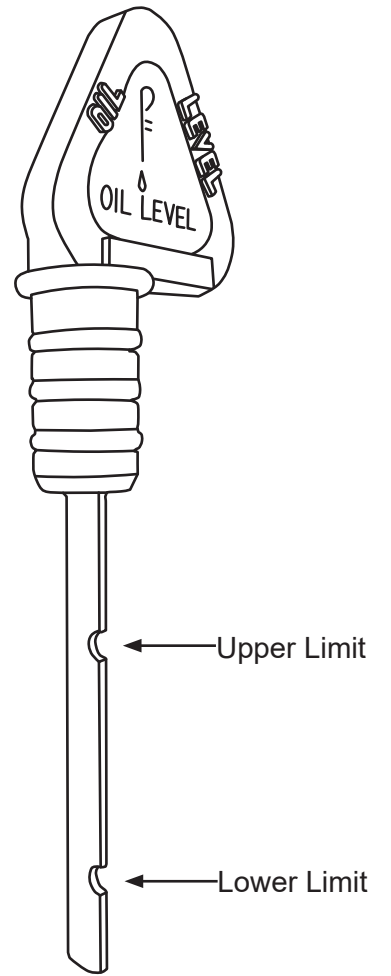

Check Pump Oil Level:

1. Make sure the pump oil level is half way through the site glass on the side of the pump. If the pump oil level is low, refer to the pump manual for oil filling instructions.

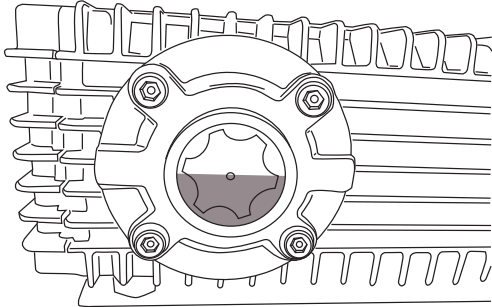

Fill Fuel Tank:

1. Remove fuel cap, fill fuel tank with fresh #2 diesel fuel, then replace fuel cap. Do not over fill fuel tank.

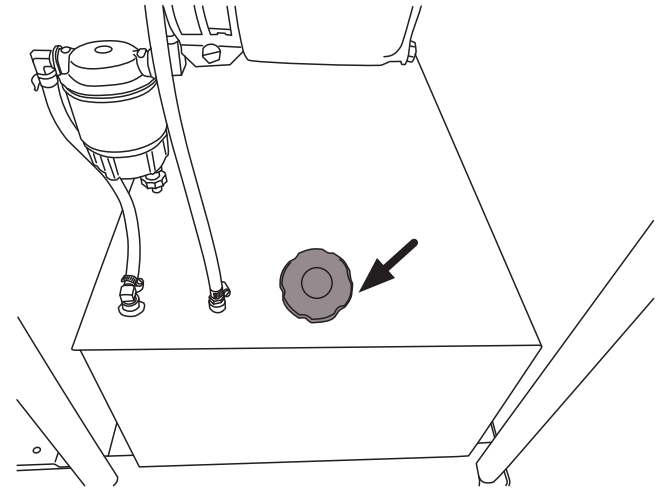

Check Radiator Coolant Level:

CAUTION:

Never open the overflow bottle or radiator when the engine is hot from running.

1. Make sure the radiator is full of coolant. If the level is low, add coolant to radiator. If equipped with an overflow bottle, also ensure that it is filled to its halfway point.

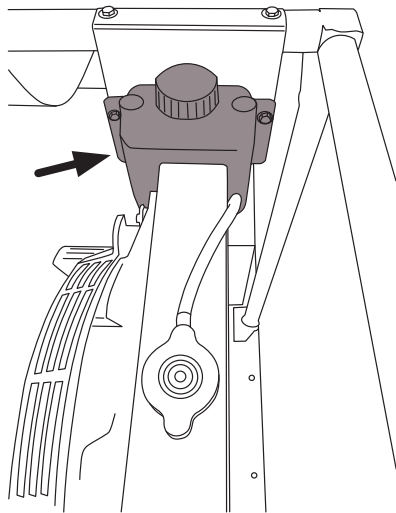

Connect Hoses and Assemble Spray Gun:

1. Make sure the inlet screen is clean, inside the pump inlet, and has the convex side facing out.

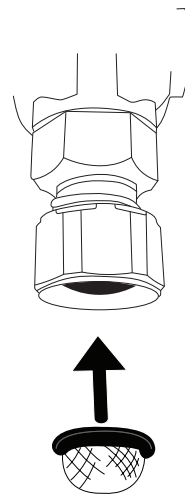

2. Turn on the water supply and run it for 30 seconds to purge any dirt or debris from the supply hose. Then, turn off the water supply and thread the water supply hose into the pump inlet.

NOTE: Water supply must be cold.

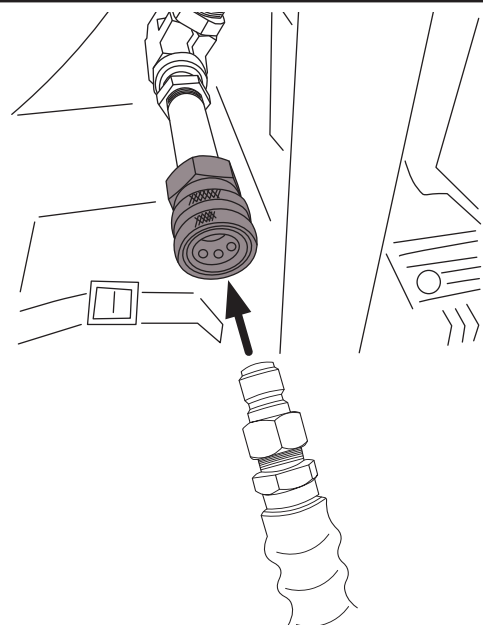
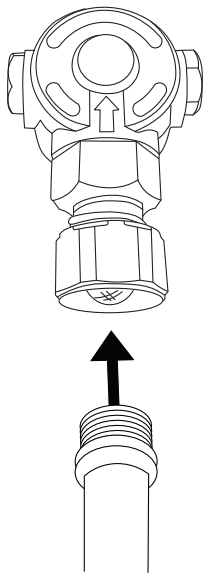

3. Insert the male quick-connect (QC) plug on the high-pressure hose into the female QC hot water outlet.

WARNING! The threads on the lance and gun coupler can be easily cross threaded resulting in an improper assembly. An improper assembly of the gun and lance can result in personal injury. Do not use if the threads on the gun coupler and or lance are cross threaded.

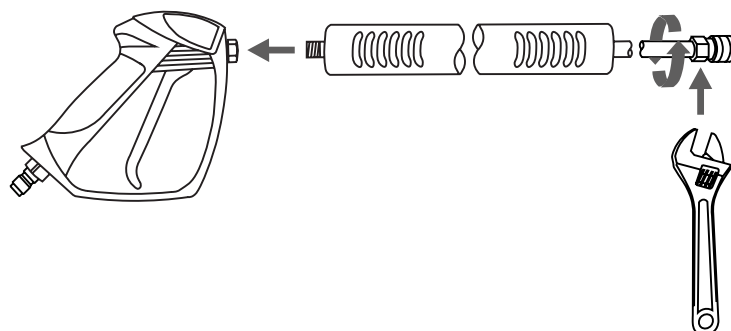

4. Hand thread the lance clockwise into the gun. Be careful not to cross-thread the gun and lance. Using an adjustable wrench, tighten the lance by placing the wrench on the flats of the nozzle quick-connector.

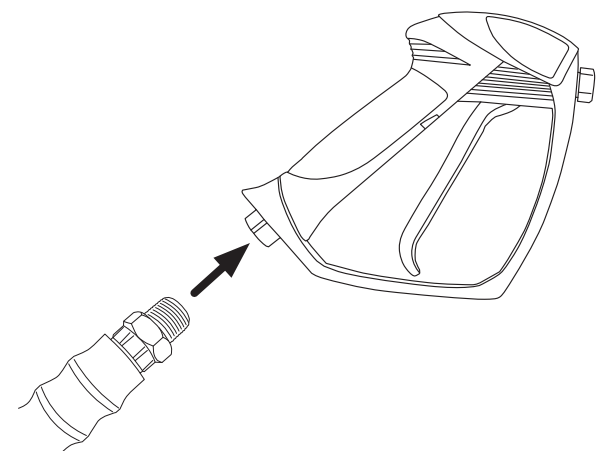

5. Thread the high-pressure hose onto the spray gun inlet.

6. Turn on the water supply, aim the spray gun in a safe direction, then squeeze and hold the trigger for at least 60 seconds or until the water runs steady and all the air is purged from the pump, heater coil and hoses. When completed, engage the trigger lock.

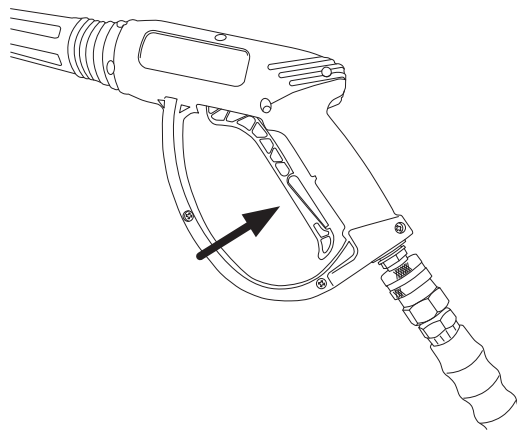

7. Select the correct nozzle for your cleaning job per nozzle selection chart in this document and install it onto the lance by pulling the quick-connect coupler back, inserting the nozzle, then releasing the coupler allowing it to snap back in place.

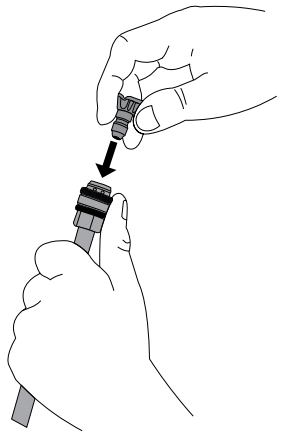

Using Chemicals:

1. Attach the open end of the soap hose to the barbed fitting on the pump.

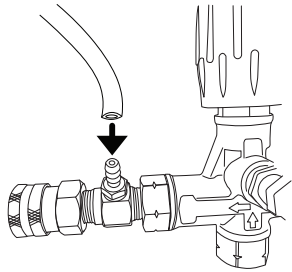

2. Place the filtered end of the soap hose into a container of soap.

NOTE: Use only soaps that are approved for pressure washer use.

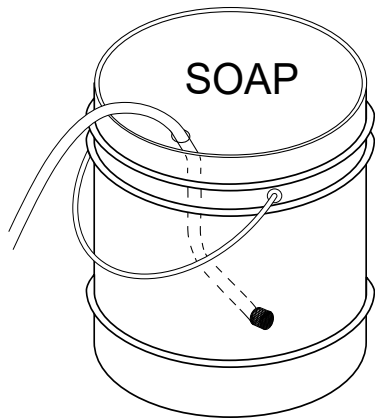

3. If the engine is running, make sure the trigger lock is in the locked position before removing and installing nozzles.

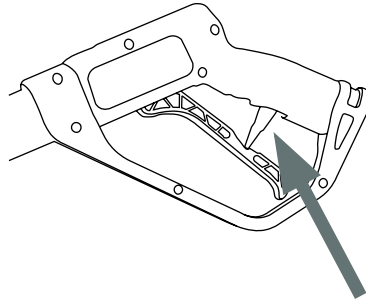

4. Insert the black nozzle into the spray wand.

NOTE: Soaps will not siphon if the black soap nozzle is not installed on the spray wand.

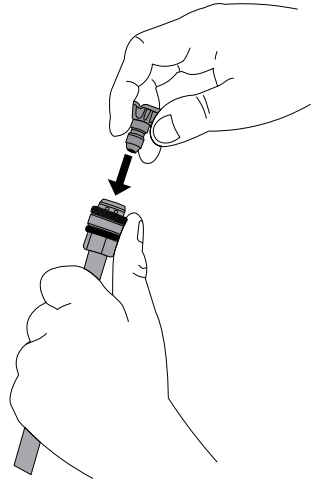

NOTE: After using soap, place the filtered end of the soap hose into a container of clean water and run pressure washer drawing clean water through the hose and pump until the system is thoroughly rinsed. If soap or other chemicals remain in the pump, the pump could be damaged. Pump damage from soap or chemical residue is not covered under warranty.

Start the Engine: Please refer to the engine manual for engine starting instructions.

1. Turn engine key to the 1st position.
2. Wait for orange Glow Plug light to turn off.
3. Turn the key to the 2nd position to start the engine. Once the engine has started, allow the key to return to the 1st position.

NOTE. If the engine does not start after 20 seconds, allow the starter to cool for 1 minute before trying once again to start the engine.

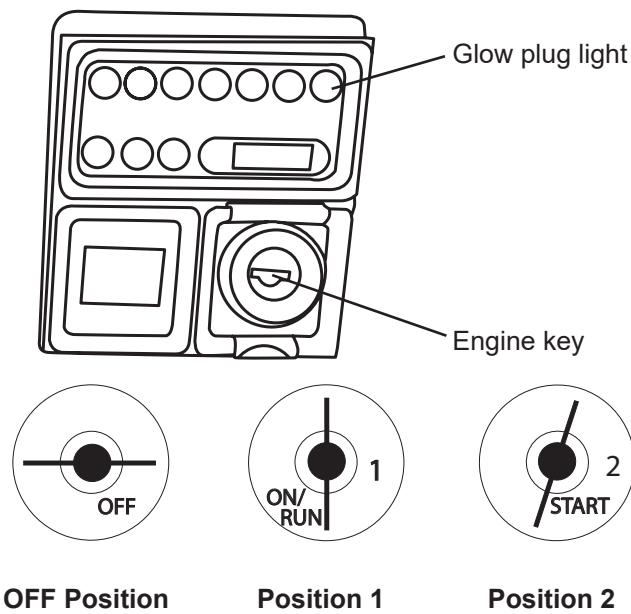

Igniting Water Heater:

NOTE: DO NOT try to ignite the burner unless the engine is running.

1. Turn on the burner by clicking the burner switch to the ON position.

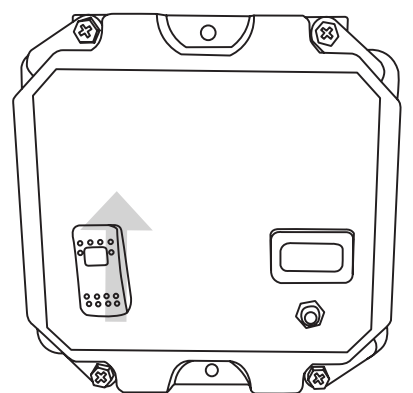

Selecting a Nozzle:

Color	Spray Pattern	Uses	Surfaces
Red	0°	Spot cleaning hard, unpainted surfaces and high-reach areas	Unpainted metal and concrete DO NOT use on wood
Yellow	15°	Intense cleaning of unpainted surfaces	Grills, driveways, concrete and brick walkways, unpainted brick and stucco
Green	25°	Standard cleaning nozzle for most applications	Yard tools, sidewalks, lawn furniture, unpainted siding, stucco, gutters, eaves, concrete, and brick surfaces
White	40°	Cleaning painted or delicate surfaces	Autos, trucks, RVs, boats, wood, painted brick, painted stucco, vinyl, and painted siding
Black	Soap	Applying cleaning solutions	Safe on all surfaces. Always verify compatibility of cleaning solutions prior to use.

NOTE: Always make sure the nozzle is properly installed by tugging on it after inserting it into the quick connector before using the pressure washer.

Pressure Washing Tips:

1. Set the trigger lock on the spray gun when not in use.
2. A wider spray equals faster cleaning, while tighter spray equals deeper cleaning.
3. Do not aim the nozzle straight at a surface. Hold the wand at a 45-degree angle to the surface and at a distance that cleans well without causing damage.
4. Keep the nozzle about 4-feet away from siding to prevent damage to surfaces.
5. Wash siding by starting at the bottom and working your way up, then rinse from the top down.
6. Avoid driving water up behind siding.
7. For even cleaning, use overlapping strokes.
8. Work in smaller areas and do not let soap dry on surfaces.
9. Whenever freezing weather is possible, remove any remaining water from the high-pressure hose, spray gun assembly and the pump as indicated in the pressure washer Use and Care Manual. We suggest protecting the pump by using Simpson® Pump Guard.