

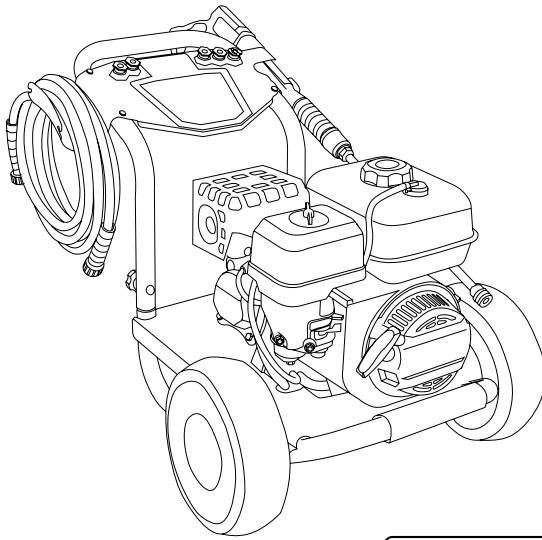



PRESSURE WASHER

USE AND CARE MANUAL

PS61251, PS61254



 **LOOK BEFORE YOU PUMP!**

— Ethanol Percentage —

<10% **OK** **NO** 15%–30%–85%



READ THIS MANUAL CAREFULLY BEFORE OPERATION

Failure to follow the instructions and safety precautions in this manual can result in property damage, serious injury and/or death.

If your pressure washer is not working or if there are parts missing or broken, please **DO NOT RETURN IT TO THE PLACE OF PURCHASE**. Contact our Customer Service Department by calling **1-877-362-4271** or emailing **cservice@fna-group.com**

SAVE THIS MANUAL FOR FUTURE REFERENCE

NOTE: Photographs and line drawings used in this manual are for reference only and may not represent your specific model.

NOTES

THIS PAGE WAS INTENTIONALLY LEFT BLANK

SAVE THIS MANUAL FOR FUTURE USE

Keep this manual for future reference. This manual should be considered a permanent part of the product and stay with it. This manual should be available to anyone operating the product(s) it covers. This manual should remain with the product(s) it covers if sold to a new owner. If the manual becomes damaged, lost, or otherwise unusable, you may download a new copy from the product pages at <https://www.simpsoncleaning.com/> or contact customer support by calling 1-877-362-4271.

Write down the model number, serial number, and purchase date of this product in the spaces provided below then keep this manual with the purchase receipt(s) for future reference.

Model Number:

Serial Number:

Purchase Date:

TABLE OF CONTENTS

SAFETY INSTRUCTIONS	4
Read this Manual Before Operating	4
Additional Instructions	4
Hazard Alert Symbols	4
DISCLAIMERS	5
PERSONAL PROTECTIVE EQUIPMENT	5
UNPACKING	6
ASSEMBLY	6
Install Knob-style Handle	6
Assemble the Spray Gun	7
Organize Accessories	7
COMPONENT LOCATION	8
CONNECTING HOSES	10
PURGING AIR FROM THE PUMP	11
NOZZLES	12
Nozzle Selection	12
Nozzle Installation	12
USING CHEMICALS	13
OPERATING CHECKLIST	14
Location	14
High Altitude Operation	15
Operating Conditions	15
Checking the Engine Oil	16
Checking Fuel	18
STARTING THE ENGINE	20
SHUTTING OFF ENGINE	21

OPERATION TIPS	22
Terms	22
Preparation	22
Pressure Washing	22
Adjusting Pressure	22
TROUBLESHOOTING	23
MAINTENANCE	25
Maintenance	25
Cleaning the Pressure Washer	25
Connections	25
Nozzle Cleaning	26
Water Inlet Filter	26
Pump Maintenance	27
Engine Maintenance	27
STORAGE AND TRANSPORTATION	27
Storing for Two Months or Less	27
Storing for More Than Two Months	28
Transportation	28
USING SIMPSON® PUMP GUARD	29
WARRANTY	30

SAFETY INSTRUCTIONS



READ THIS MANUAL BEFORE OPERATING

This manual contains important safety information and instructions. **Do not** operate this product until you have read, and completely understand all safety, operation, and maintenance instructions listed in this manual. Failure to follow the information contained in this manual will result in property damage, injury, and/or death.

NOTE: The warnings and precautions discussed in this manual cannot cover all conditions and situations that may occur. The operator must understand awareness and caution are factors which cannot be built into this product and so must be exercised by the operator.



ADDITIONAL INSTRUCTIONS

Along with this manual, be sure to read any additional instructions provided both on and with the product, attached equipment, accessories, and the engine powering the product. Pay careful attention to all additional safety rules and instructions on proper startup, operation, and shutdown procedures. Always use any recommended protective apparel that may be needed to operate the equipment safely.



HAZARD ALERT SYMBOLS

Be sure to understand the safety symbols and definitions listed below. Each symbol contains one of four words: **DANGER**, **WARNING**, **CAUTION**, **NOTICE**, indicating different levels of hazard severity. These symbols are used throughout this manual and are followed information about a specific hazard, the consequences of the hazard, and instructions on how to avoid the hazard. Failure to heed these symbols and follow the instructions provided with them will result in property damage, injury, and/or death.



DANGER:

Indicates an imminently dangerous situation, which if not avoided, will result in property damage, serious injury, and/or death.



WARNING:

Indicates a potentially hazardous situation, which if not avoided, could result in property damage, serious injury, and/or death.



CAUTION:

Indicates a hazardous situation, which if not avoided, could result in property damage and/or minor to moderate injury.

NOTICE

Indicates information considered important, but not directly hazard related.



CALIFORNIA PROPOSITION 65 WARNING

This product and the engine exhaust can expose you to chemicals which are known to the state of California to cause cancer, birth defects, or other reproductive harm. For more information on California Proposition 65, go to www.P65Warnings.ca.gov.



POLYCYCLIC AROMATIC HYDROCARBON WARNING

The air filter element and air box assembly may contain polycyclic aromatic hydrocarbons (PAHs). Some PAHs may cause cancer. To avoid exposure to PAHs, wear gloves when performing air filter maintenance.

DISCLAIMERS

- All information in this publication was based on the latest product information available at the time of printing. The FNA Group reserves the right to update, change, and/ improve the product and this document at any time, without notice, and without incurring any obligation.
- This manual may cover more than one machine. The pictures and figures in the manual should be used for reference only. There may be differences between your product and the pictures, drawings, and diagrams in this manual.

PERSONAL PROTECTIVE EQUIPMENT (PPE)

It is important to understand what personal protective equipment (PPE) should be utilized when using your pressure washer. Below is a list of PPE items that should be utilized at all times when using the pressure washer.

Hearing - Ear plugs or muffs to protect your hearing.

Vision - Safety glasses or goggles to protect your eyes.

Clothing - Long pants to protect your legs from flying debris.

Shoes - Shoes that fully cover your feet to protect against debris and over spray.

UNPACKING

Follow the steps outlined in this section to unpack and assemble your pressure washer. If you have any questions regarding the unpacking or assembly of your pressure washer, please have your model number and serial number ready, then contact customer support at 1-877-362-4271 or email cservice@fna-group.com.

1. Place the shipping carton on a solid, flat surface.
 2. Carefully cut the top of the carton open.
 3. Carefully cut each corner of the carton from top to bottom.
 4. Lay each side of the carton flat on the ground.
 5. Remove everything from the carton.
-

ASSEMBLY

Install knob-style handle

Slide the handle onto the frame then secure it with the included knobs and bolts.

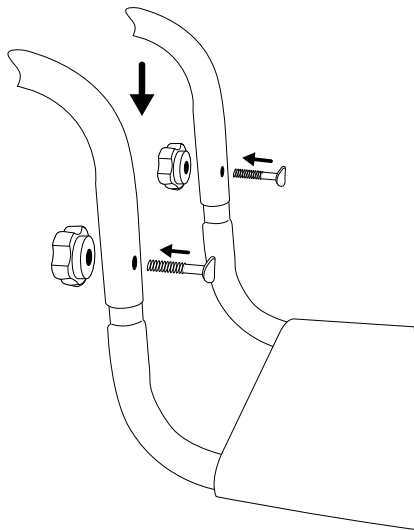

Assemble the spray gun

1. Thread the lance into the spray gun.

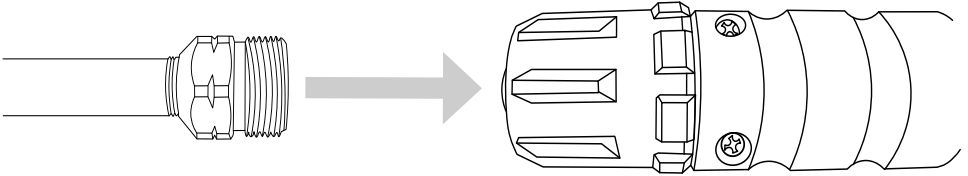

Organize accessories

1. Place the spray gun and lance assembly into the holder on the dashboard.
2. Push the nozzles into the rubber grommets on the dashboard. Note: the dashboard label indicates correct nozzle placement.
3. Hang the high-pressure hose on the holder.

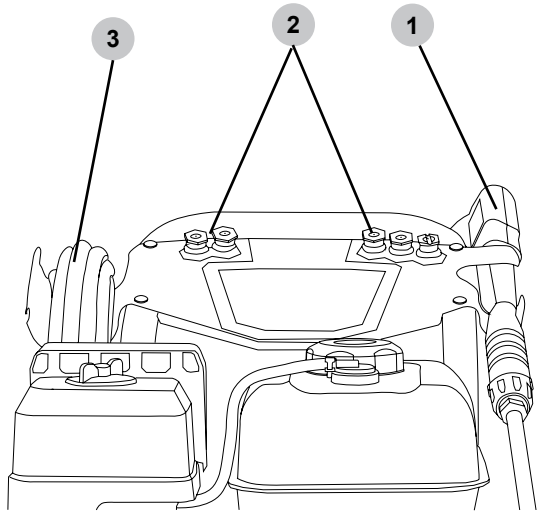

WARNING:

OPERATING CHECKLIST

Attempting to start the engine incorrectly or using the pressure washer incorrectly can result in engine and/or pressure washer damage, and may cause serious injury or death. To avoid these hazards, be sure to read, understand, and follow the steps outlined in the OPERATING CHECKLIST section of the owner's manual before starting the engine, and follow all the guidelines for proper use of the pressure washer.

COMPONENT LOCATION

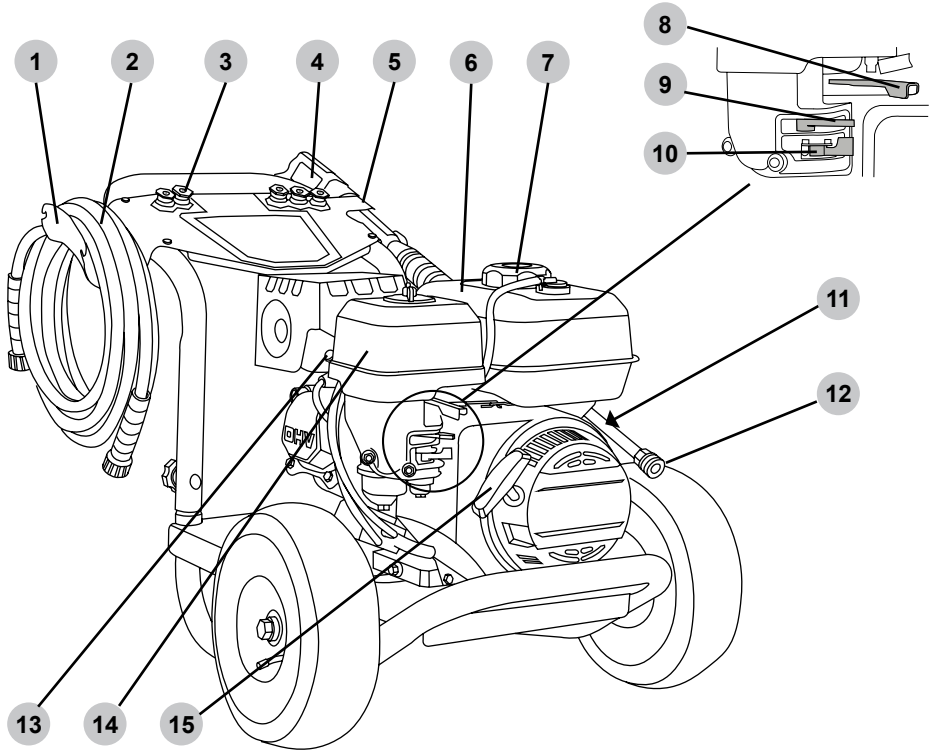

1. Hose hanger
2. High-pressure hose
3. Nozzle holder
4. Spray gun
5. Spray gun holder
6. Fuel tank
7. Fuel tank cap
8. Engine throttle
9. Engine choke
10. Engine fuel valve
11. Engine ignition switch (not shown)
12. Spray wand quick connector
13. Spark plug
14. Air filter cover
15. Engine recoil starter

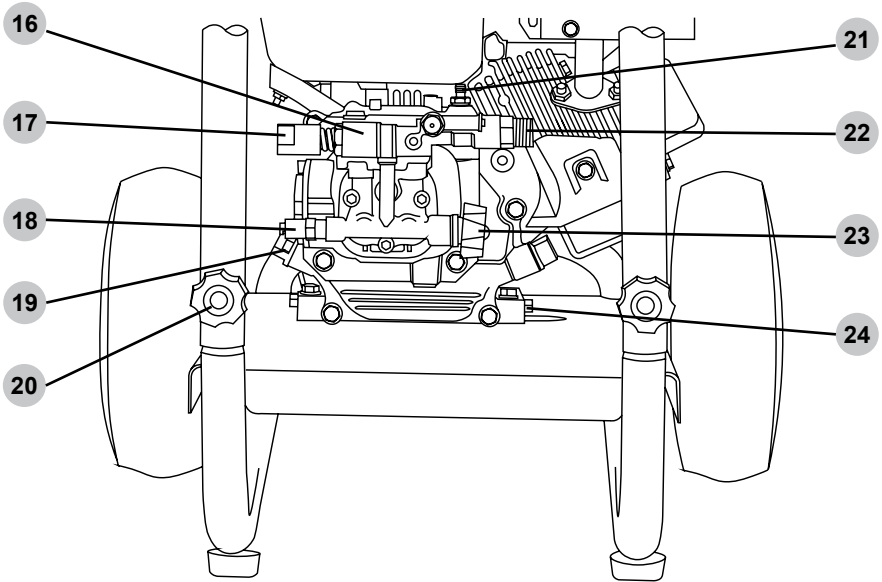

- 16. Pump
- 17. Unloader (If equipped)
- 18. Thermal relief valve
- 19. Engine oil fill cap / dipstick
- 20. Handle retaining knobs and bolts
- 21. Soap injection barb fitting
- 22. High-pressure pump outlet
- 23. Low-pressure pump inlet
- 24. Engine oil drain plug

CONNECTING HOSES

Before connecting a water supply hose, be sure the water supply is capable of providing an uninterrupted source of clean, cold water at a minimum rate of 5 gallons per minute (GPM) and 20 pounds per square inch (PSI) of pressure. Once a proper water supply is secured, follow the instructions below to connect both the water supply and high-pressure hoses to the pressure washer.

1. Verify the inlet screen is free of any dirt or debris and is in place with the convex side facing out.

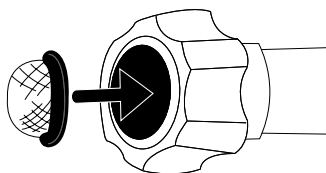

2. Turn on the water supply and run for 30 seconds to purge any debris from the supply hose. Then, turn off the water supply and thread the water supply hose into the pump inlet.

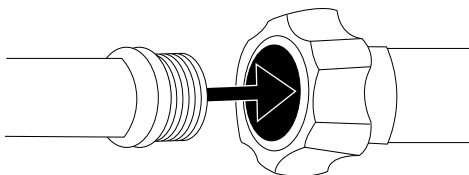

3. Thread the high-pressure hose onto the pump outlet.

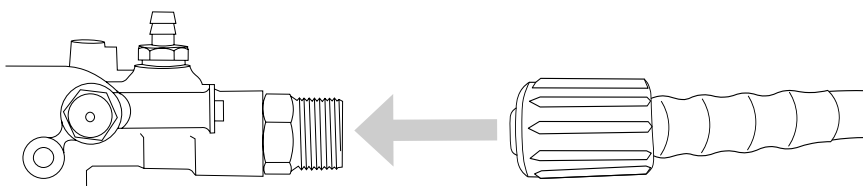

4. Thread the high-pressure hose onto the spray gun.

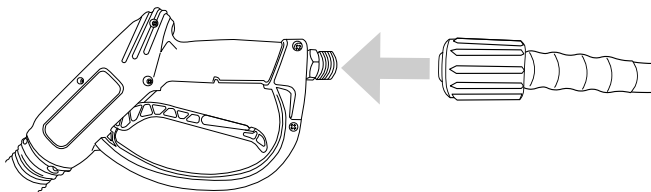

PURGING AIR FROM THE PUMP



NOTICE PUMP PURGING

Running a pressure washer pump without water will severely damage the pump seals and other internal components. To avoid this hazard, make sure your water supply is uninterrupted and at least 5 GPM at 20 PSI, and always purge the air your pressure washer pump before starting the engine.



! WARNING: INJECTION INJURY

The high pressures created by a pressure washer can cause fluid injection injuries, severe lacerations, amputations, and / or death. To avoid these hazards, always aim the spray gun and lance in a safe direction when using the pressure washer and never attempt to touch a leak in a high-pressure hose or fitting.

A pressure washer pump is designed to operate with water flowing through it. Water lubricates and cools the internal components of the pump. Running a pressure washer pump without water will severely damage the pump seals and other internal components. Damage caused by running a pressure washer pump without water is not covered under warranty. Be sure to follow the instructions below to correctly purge the air from your pressure washer pump before starting the engine.

1. Connect all the hoses by following the steps outlined in the **CONNECTING HOSES** section of this manual then turn on the cold water source.

2. Aim the spray gun in a safe direction then squeeze and hold the trigger for at least 30 seconds or until the water runs steady and all the air is purged from the pump and hoses.

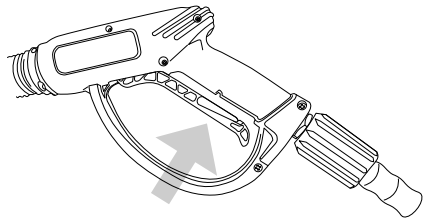





3. Check hoses and connections for leaks. If leaks are found, turn off the machine, aim the spray gun in a safe direction and squeeze the trigger to relieve any built up pressure in the system. Never attempt to touch a leak in a high-pressure hose or fitting. Never attempt to repair a high-pressure hose.

NOZZLES

Nozzle Selection

The nozzles supplied with the pressure washer have specific spray patterns designed to clean different surfaces. Using the incorrect nozzle can damage surfaces. Refer to the table below to select the correct nozzle before using the pressure washer. **NOTE:** The selection of nozzles included may vary with pressure washer models.

Color	5-N-1 (if equipped)	Spray Pattern	Uses	Surfaces
Red	 0° HIGH PRESSURE	0°	Spot cleaning hard, unpainted surfaces and high-reach areas	Unpainted metal and concrete DO NOT use on wood.
Yellow	 15° HIGH PRESSURE	15°	Intense cleaning of unpainted surfaces	Grills, driveways, concrete and brick walkways, unpainted brick and stucco
Green	 25° HIGH PRESSURE	25°	Standard cleaning nozzle for most applications	Yard tools, sidewalks, lawn furniture, unpainted siding, stucco, gutters, eaves, concrete, and brick surfaces
White	 40° HIGH PRESSURE	40°	Cleaning painted or delicate surfaces	Auto, truck, RV, marine, wood, painted brick, painted stucco, vinyl, and painted siding
Black	 SOAP LOW PRESSURE	Soap	Applies cleaning solutions	Safe on all surfaces. Always verify compatibility of cleaning solution(s) prior to use.



NOTICE SPRAY DAMAGE

High-pressure spray can damage plants and other surfaces. To avoid causing damage, cover plants before spraying near them, refer to the Nozzle Selection table in this manual for correct nozzle selection, and test surfaces before spraying to make sure they are strong enough to withstand high-pressure spray.

Nozzle Installation

To place a nozzle into the spray wand, pull the quick-connect coupler back, insert the nozzle, then release the coupler allowing it to snap back in place. Once installed, pull on the nozzle to make sure it secure.

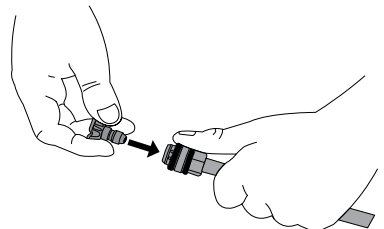

USING CHEMICALS



NOTICE

VOLATILE LIQUIDS

Pressure washing with volatile, flammable, or corrosive liquids could cause pressure washer damage, fire, or explosion resulting in severe injury and/or death. To avoid these hazards, use only approved soaps and chemicals, do not attempt to pressure wash with volatile, flammable, or corrosive liquids, and NEVER use bleach.

1. Attach the open end of the soap hose to the barbed fitting on the pump.

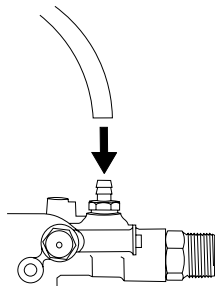

2. Place the filtered end of the soap hose into a container of soap.



3. Insert the black nozzle into the spray wand per the Nozzle Installation section of this manual. **NOTE:** Soaps will not siphon if the black soap nozzle is not installed on the spray wand.

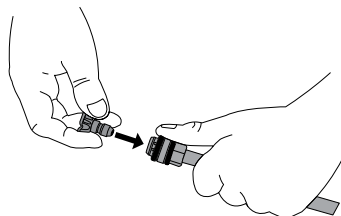

4. After using soap, place the filtered end of the soap hose into a container of clean water and run pressure washer drawing clean water through the hose and pump until the system is thoroughly rinsed. If soap or other chemicals remain in the pump, the pump could be damaged. Pump damage from soap or chemical residue is not covered under warranty.

OPERATING CHECKLIST

Location

Place the pressure washer on a level surface outside in a well-ventilated area before operating. Keep all flammable materials at least five feet away from all sides of the product.

- Never use pressure washer inside a house, garage, or any other kind of enclosure even if doors and windows are open. Run engine outside at least 20 feet (6 meters) away from windows, doors, and vents. Carefully consider wind direction and air currents when using pressure washer outside to avoid breathing in engine exhaust.
- Following the manufacturer's instructions and recommendations, install battery operated carbon monoxide alarms in any occupied buildings near the running engine.
- If you experience headache, nausea, dizziness, sleepiness, or weakness while pressure washer is running, move to fresh air and seek medical attention immediately.



WARNING: TOXIC FUMES

Engine exhaust contains carbon monoxide, an odorless, colorless, poisonous gas. Running an engine indoors will kill you in minutes. Never use this product inside a house, garage, or any other kind of enclosure even if doors and windows are open. Run engine outside at least 20 feet (6 meters) away from windows, doors, and vents. Carefully consider wind direction and air currents when using this product outside to avoid breathing in engine exhaust. Always use a carbon monoxide detector in any occupied buildings near the running engine.

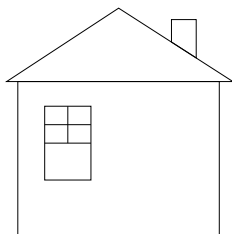
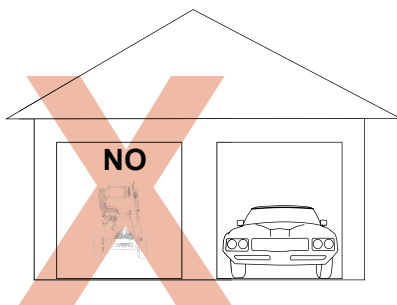
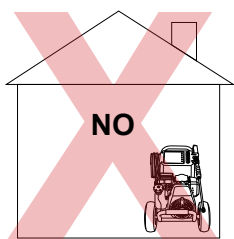

YES



High Altitude Operation

This engine will have proper engine performance and emission control when it is operated at or below an altitude of 5000 feet (1524 meters). This engine requires a high-altitude carburetor kit to ensure proper engine performance and emission control when operated at altitudes above 5000 feet (1524 meters). Operating the machine with the wrong engine configuration above 5000 feet (1524 meters) may increase its emissions, decrease fuel efficiency, and hurt performance. To obtain a high altitude carburetor kit, contact your nearest authorized service center.



NOTICE ALTITUDE

Operating the engine with a high-altitude carburetor jet kit at an altitude below 5000 feet (1524 meters) will cause the engine to run too hot. Overheating the engine could result in serious engine damage. To avoid this hazard, make sure the correct carburetor kit is installed and the air/fuel mixture is set correctly for your altitude.

Operating Conditions

Before each use, check for loose or damaged parts, leaks, and/or any other condition that may affect proper operation. Repair or replace all damaged and/or defective parts immediately. Always keep all safety guards in place and in proper working order. For safety reasons, the manufacturer recommends all maintenance and repairs be performed by an authorized service center.

Before starting engine, remove any excessive dirt and debris from cooling vents, exhaust, and starter recoil areas. Always operate the pressure washer on a level surface and never move or tip the pressure washer while operating. Use pressure washer only for its intended purpose. If you have questions about the proper use of your pressure washer, please contact customer support at 1-877-362-4271 or cservice@fna-group.com.



WARNING: UNTRAINED OPERATION

Untrained persons, young children, and pets can be seriously injured or killed if allowed to incorrectly operate or play with running pressure washer. To avoid these hazards, be sure anyone operating the pressure washer receives proper instructions, understands safe operation, and has read the owner's manual before operating this product. Do not let children operate the pressure washer without parental supervision. Keep young children and pets away from the pressure washer while it is running. Always turn off the pressure washer before leaving the area.



WARNING: INSPECT BEFORE OPERATING

Failure to inspect this product before use could create a hazardous situation resulting in product damage, serious injury, and/or death. To avoid these hazards, inspect the pressure washer before each use. Check for loose or damaged parts, signs of oil or fuel leaks, missing guards, plugged cooling vents, or any other condition that may affect proper operation. Repair or replace all damaged or defective parts and keep all safety guards in place and in proper working order before using the pressure washer.



! WARNING: INJECTION INJURY

The high pressures created by a pressure washer can cause fluid injection injuries, severe lacerations, amputations, and / or death. To avoid these hazards, always aim the spray gun and lance in a safe direction when using the pressure washer and never attempt to touch a leak in a high-pressure hose or fitting.



! CAUTION: HOT SURFACES

A running engine produces heat. The surfaces of the engine, other related components, and engine exhaust gas get hot enough to cause mild moderate burns or ignite materials on contact. To avoid burns, do not touch engine surfaces or exhaust gases while operating and allow engine to cool completely before moving, touching, or performing any maintenance. To avoid a fire, keep all flammable materials at least five feet away from all sides of the product.



! WARNING: MOVING PARTS

This product has many parts that move at high speeds. Moving parts can cause crushing injuries, broken bones, severe lacerations, and/or traumatic amputations. To prevent injury, never place fingers, hands, feet, or other body parts near running engine. Never operate product with covers, shrouds, or other guards removed. Do not wear loose-fitting clothing, dangling drawstrings, or any other hanging items that could become entangled in moving parts while operating. Tie up long hair and remove jewelry before operating.

Checking the Engine Oil



! CAUTION: HOT OIL

Hot oil can cause serious burns. To prevent getting burned when changing or checking the engine oil, wear gloves and change the oil when the engine is warm but not hot.



NOTICE LOW OIL SENSOR

The low oil sensor (if equipped) will automatically stop the engine when the oil level falls below the safe limit. To avoid an unexpected shutdown, check the oil level regularly, fill to the upper limit, and always operate engine on a level surface.



NOTICE

FILL ENGINE BEFORE USE

The engine is shipped from the factory without oil. Running the engine without oil will result in severe engine damage and void the warranty. To avoid causing engine damage and voiding the warranty, fill the engine with the recommended oil type before starting.



NOTICE

USE CORRECT ENGINE OIL

Oil is a major factor in the performance and service life of any engine. Using the incorrect oil may damage the engine and void the warranty. To avoid causing engine damage and voiding the warranty, check and change oil as required using the correct engine oil.

1. Check oil with pressure washer on a level surface and the engine off.
2. Unscrew the engine oil dipstick and pull it out, then wipe dipstick clean.
3. Place clean dipstick into filler neck but do not thread it in, leave it rest it on the filler neck.
4. Remove the dipstick from filler neck and check oil level. Oil level should be at the upper oil limit on the dipstick.
5. If level is low, add the recommended oil to the crankcase until the level reaches the upper limit on the dipstick. See the engine manual for recommended oil.
6. Install the dipstick and tighten cap by threading it into the filler neck.

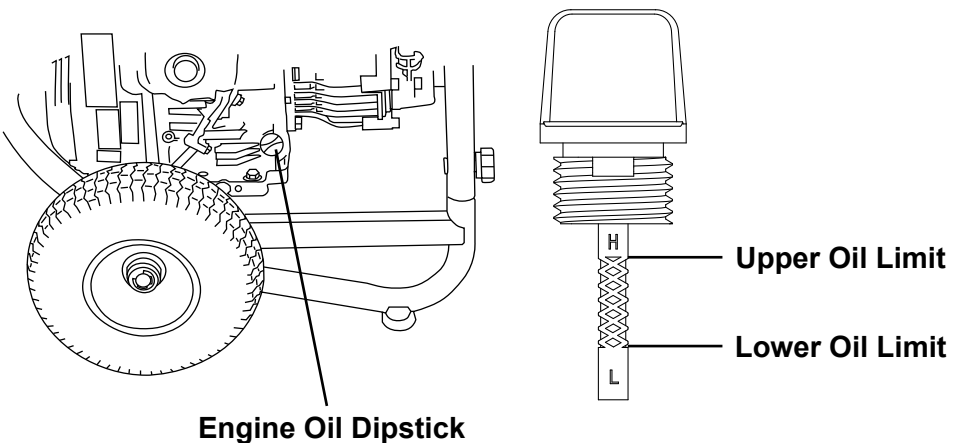

Checking Fuel



WARNING: REFUELING

Gasoline is highly flammable and gasoline vapors are extremely explosive. Fire and explosions can cause severe burns and/or death. Keep gasoline away from flames, sparks, and other ignition sources. Refuel outdoors in a well-ventilated area with the engine stopped and cool. Wipe up any spilled gasoline and allow engine to dry before starting. Keep a fire extinguisher handy while refueling. Do not operate engine with leaks in the fuel system. Do not store gasoline near other flammable materials.



NOTICE OLD GASOLINE

Old gasoline can create deposits that clog fuel systems causing hard starting and poor performance. Damage caused by old fuel is not covered by warranty. To minimize deposits, avoid old fuel related performance issues, and prevent costly repair work, do not use gasoline that is older than 30 days.



NOTICE ALCOHOL BLENDS

Using gasoline with an alcohol blend greater than 10% (E10) will damage the engine. Damage caused by using an alcohol blend of 15% (E15), 85% (E85), or any other alcohol blend higher than 10% (E10) is not covered under warranty. To avoid engine damage caused by an alcohol blend that is too high, use gasoline with 10% (E10) alcohol or lower.



NOTICE GASOLINE ADDITIVES

The use of fuel system cleaning additives can damage the engine and fuel systems. Damage caused by the use of fuel system cleaning additives is not covered by warranty. To avoid engine and fuel system damage, do not use any fuel system cleaning additives.



CAUTION: FUEL TANK PRESSURE

Gasoline vapor can build up inside the fuel tank creating pressure. This pressure may increase when the engine is hot from running. Opening the fuel tank under pressure can cause rapid escape of flammable vapors and possible fuel spills that may ignite from contact with hot engine surfaces resulting in burn hazard. To avoid these hazards, always allow the engine to cool for at least 2 minutes before removing fuel cap and loosen the fuel cap slowly to relieve any pressure in the tank.



NOTICE GASOLINE STORAGE

It is important to prevent gum deposits from forming in essential fuel system parts, such as the carburetor, fuel filter, fuel hose or tank during storage. Alcohol-blended fuels (also called gasohol, ethanol, or methanol) attract moisture, which leads to separation and formation of acids during storage. Acidic fuel and gum deposits can damage the engine's fuel system while in storage. Damage caused by the use of old, stale, or contaminated fuel are not covered under warranty.



NOTICE DO NOT OVERFILL FUEL TANK

Overfilling the fuel tank can result in carbon canister damage (if equipped), poor engine performance, and void the warranty. To avoid these hazards, do not fill the fuel tank above the maximum level.

1. Check fuel with the engine off and pressure washer on a level surface.
2. Remove fuel tank cap, check fuel level, then fill fuel tank if needed. For fuel cap location see the COMPONENT LOCATIONS section of this manual.
3. Do not use gasoline that is older than 30 days. Use only clean and fresh regular unleaded gasoline with a minimum octane rating of 87. Do not mix oil with gasoline. Do not use gasoline that contains more than 10% ethyl alcohol. E15, E20, and E85 are not approved fuels and should not be used.
4. Do not to fill the fuel tank above the maximum fuel level to allow room for fuel expansion. For fuel capacity see the SPECIFICATIONS section of this manual.
5. Replace fuel tank cap. Never run engine without fuel cap installed.

NOTE: Using a fuel stabilizer (sold separately) when storing gasoline can help prevent problems related to storing ethanol alcohol blended gasoline. Always follow the instructions provided by the fuel stabilizer manufacturer to mix and use correctly.

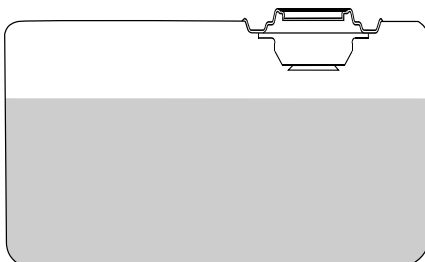

Maximum Fuel Level

STARTING THE ENGINE



! WARNING:

OPERATING CHECKLIST

Attempting to start the engine incorrectly or using the pressure washer incorrectly can result in engine and/or pressure washer damage, and may cause serious injury or death. To avoid these hazards, be sure to read, understand, and follow the steps outlined in the OPERATING CHECKLIST section of the owner's manual before starting the engine, and follow all the guidelines for proper use of the pressure washer.



NOTICE

PUMP DAMAGE

Running the pressure washer for more than two minutes without the spray gun trigger pulled will overheat the pump and possibly cause damage. The thermal relief valve will open and spray water to help cool the pump as it overheats. To avoid overheating the pump, shut off the machine if not being used for longer than two minutes.

Starting the Engine

1. Complete the steps in the OPERATING CHECKLIST section of this manual before starting the engine. Failure to do so could cause damage to the pump or engine. If needed, refer to your Engine Owner's Manual for specific starting instructions.

2. Turn the engine switch to the ON position.

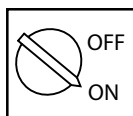

3. Slide the fuel valve to the ON position.



4. Slide the throttle to the RUN position (if equipped).

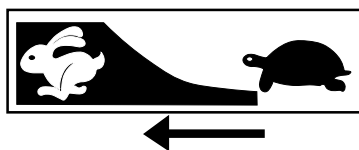

5. Slide the choke to CHOKE for starting a COLD engine. Slide to RUN for a warm engine



NOTE: The starting position of the choke will vary depending on the engine temperature. If starting a cold engine, move the choke lever towards the CHOKE position. If starting a warm engine, move the choke lever towards the RUN position.

6. Pull the recoil slowly until resistance is felt, then pull rapidly to start the engine.

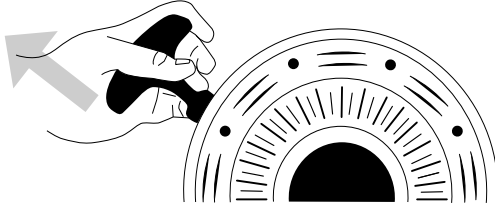

WARNING:

RAPID RETRACTION

Rapid retraction (also known as kickback) of the engine recoil starter cord will pull your hand and arm towards the engine faster than you can let go of the handle resulting in sprains, broken bones, lacerations, and/or traumatic amputations. Kickback is caused by damage to the engine crankshaft key, compression release failure, and/or improper starting techniques. To avoid kickback follow the appropriate maintenance schedule, starting instructions and have repair work done by an authorized service center.

7. Once the engine starts, slowly move the choke lever to RUN as the engine runs. If the engine falters, move the choke toward CHOKE until the engine has warmed up.



SHUTTING OFF ENGINE



NOTICE

PUMP DAMAGE

Turning off the water supply to your pump with the engine running will damage the pump. Damage caused by running the pump without water is not covered under warranty. To avoid this hazard always turn off the engine before shutting off the water supply.

1. Slide the throttle to the SLOW position (if equipped).
2. Turn the engine switch to the OFF position.
3. Slide the fuel valve to the OFF position.
4. Turn off the water supply.
5. Squeeze the spray gun trigger to relieve the pressure in the hose and pump.
6. Allow the engine to cool completely before handling and storage.

OPERATION TIPS

Terms

- PSI - Pounds per square inch (PSI) is the unit to measure the pressure of water. In relation to a pressure washer, the higher the PSI number, the greater the pressure and stripping power produced.
- GPM - Gallons per minute (GPM) is the flow rate of water. In relation to a pressure washer, the greater the GPM, the greater the flow or rinsing power produced.
- CU - Cleaning units express the efficiency of the pressure washer. Cleaning units are calculated by multiply the PSI by the GPM. The higher the CU, the more efficient the pressure washer.

Preparation

- Read all warning and instructions in this and all manuals that came with the pressure washer.
- Remove all toys, bikes, lawn furniture, etc. from the work area if they are not to be cleaned.
- Sweep any loose dirt and debris from the surface you will be pressure washing.
- Cover nearby plants to avoid damaging them with the pressure washer spray.
- Use caution when spraying windows. Always use the white, 40° nozzle and stay at least 4 feet away.
- Lay tarps down to collect paint chips and other debris blown off by the spray. Exterior paints used before 1977 may contain lead and will produce chips that will need to be collected and disposed of at a hazardous waste facility.

Pressure Washing

- A wider spray equals faster cleaning, while a tighter spray equals deeper cleaning.
- Keep the nozzle about 4 feet away from siding to avoid damage.
- Start washing siding at the bottom and work your way up, then rinse from the top down.
- Avoid driving water up behind siding.
- Use overlapping strokes for even cleaning.
- Work in small areas to keep the soap from drying.
- Do not aim the nozzle straight at the surface. Hold the wand at a 45° angle to the surface at a distance that cleans well without causing damage.

Adjusting Pressure

The pressure setting is preset at the factory to achieve optimum pressure and cleaning. If you should need to lower the pressure, it can be accomplished by the following methods.

- Back away from the surface to be cleaned. The further you position the nozzle from the surface to be cleaned, the lower the pressure to reach the surface.
- Change to the white, 40° nozzle. This nozzle produces a lower pressure, wider width spray.

Your unit may be equipped with an addition feature that allows you to adjust the pressure.

To lower the pressure, turn the knob counter-clockwise to the desire pressure.

To return the pressure to the factory setting, turn the knob clockwise until it stops.

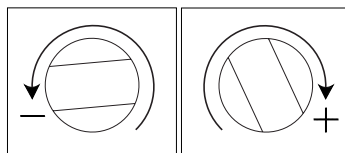

NOTE: Do not overtighten the pressure control knob. If overtightened, the knob **COULD** break causing immediate loss of pressure and costly repairs not covered by the warranty.

TROUBLE SHOOTING

ISSUE	POSSIBLE CAUSE	SOLUTION
<p style="text-align: center;">Engine will not start.</p> <p style="text-align: center;">Refer to the Engine Owner's Manual for more engine troubleshooting information.</p>	The fuel tank is empty.	Add fresh fuel.
	Water pressure in the pump is preventing the engine from rotating.	Aim the spray gun in a safe direction then pull the trigger to release water pressure in the pump.
	Engine choke is in the wrong position.	Refer to the STARTING ENGINE section of this manual for the correct choke position.
	The spark plug lead is not attached to the plug.	Connect spark plug lead.
	Engine switch is in the OFF position.	Turn the engine switch to the ON position.
	Engine fuel valve is turned OFF.	Turn fuel valve ON.
	Engine oil is low. If the engine is equipped with a Low Oil Sensor, the engine will not start.	Check engine oil level. Fill per engine manual.
<p style="text-align: center;">The pressure washer creates low or no water pressure.</p>	There is air trapped in the pump and/or hoses.	Refer to the PRIMING THE PUMP section of this manual to remove air from the pump and hoses.
	Water source is insufficient.	Make sure the water source can supply at least 5 GPM at 20 PSI.
	The nozzle is clogged.	Clean nozzle per the MAINTENANCE section of this manual.
	The water inlet screen is clogged.	Clean the water inlet screen per the MAINTENANCE section of this manual.
	The high-pressure hose is too long.	The high-pressure hose should be less than 100 feet in length.
	Engine choke is in the CHOKE position.	Move engine choke to the NO CHOKE position.

ISSUE	POSSIBLE CAUSE	SOLUTION
Will not draw in detergent.	Spray wand not in low pressure.	Insert black “soap” nozzle.
	Detergent filter clogged.	Clean the filter.
	Detergent filter is not submerged in the detergent.	Make sure the filter end of the detergent siphon hose is fully submerged in the detergent.
	Detergent is too thick.	Dilute detergent. The detergent should be the same consistency as water.
	High-pressure hose is too long.	Lengthen the water supply hose instead of the high-pressure hose.
	Detergent is dried inside of the detergent injector.	Contact customer service at 1-877-362-4271 or at cservice@fna-group.com
Water leaking at pump.	Loose connections.	Tighten the connections.
	Worn or torn O-ring.	Check and replace.
	Piston packing worn.	Contact customer service at 1-877-362-4271 or at cservice@fna-group.com
	Pump head or tubes damaged from freezing.	Contact customer service at 1-877-362-4271 or at cservice@fna-group.com
Pump or nozzle pulsates.	Nozzle obstructed.	Clean nozzle per the MAINTENANCE section of this manual.
Oil leaking from pump.	Loose drain plug.	Tighten.
	Worn drain plug O-ring.	Check and replace.
	Worn fill plug O-ring.	Check and replace.
	Pump oil overfilled.	Check for correct amount.
	Incorrect oil used.	Drain and fill with correct type and amount of oil.
	Vent plug is clogged.	Clean vent plug; blow air through vent to remove blockage. If problem persists, replace the plug.
	Oil seals worn.	Contact customer service at 1-877-362-4271 or at cservice@fna-group.com

MAINTENANCE

For safety reasons, the manufacturer recommends all pressure washer service and repairs be performed by an authorized service center. All warranty replacements or repairs must be performed by an authorized distribution or service center. To find an authorized service center near you, make a warranty claim, or get authorized warranty repair, call 1-877-362-4271 or email cservice@fna-group.com.

It is the responsibility of the owner and/or operator to have all scheduled maintenance completed before operating the pressure washer. Be sure to follow the inspection and maintenance recommendations as listed in all the manuals that came with this unit.

Maintenance

Before each use, check pressure washer for leaks, loose or damaged parts, and any other condition that may affect proper operation. Be sure all safety guards are in place and in proper working order. Inspect all air vents and cooling slots to ensure they are clean and unobstructed. Repair or replace all damaged or defective parts immediately. For safety reasons, the manufacturer recommends all pressure washer service and repairs be performed by an authorized service center.

Cleaning the Pressure Washer

Always clean the pressure washer with the engine off and cool. To clean the pressure washer, first use an air compressor set at no more than 25 PSI to clear dirt and debris from the pressure washer surfaces, vents, and cooling slots. Then, wipe the exterior clean with a damp cloth.



NOTICE CLEANING

Water can damage the pressure washer engine components if allowed to enter through cooling slots or other holes. Damage caused by water intrusion is not covered under warranty. To avoid engine water damage, do not use a pressure washer, garden hose, or any other sources of running water to clean the pressure washer engine, and never submerge the pressure washer engine in any liquids.



NOTICE CHEMICAL CLEANERS

Using chemical cleaners and/or corrosive liquids can damage the pressure washer seals and internal components. Damage caused by chemical cleaners and corrosive liquids is not covered under warranty. To avoid these hazard, only use approved cleaning chemicals, never use bleach, and always run clean water through the pressure washer after using cleaning chemicals.

Connections

Hose, spray gun, and pump connections should be cleaned and lubricated with a thin film of lithium grease regularly to prevent o-ring damage and leaks.

Nozzle Cleaning

If a nozzle becomes clogged, the pump may pulsate and spray patterns could change. If the nozzle is not cleaned, excessive pressure may develop possibly damaging the pump, or other accessories. Inspect nozzles before using them and follow the instructions in this section for the proper nozzle cleaning procedure.

1. Shut off the pressure washer.
2. Turn off the water supply.
3. Point the Spray gun in a safe direction and squeeze the trigger to relieve water pressure.
4. Remove the nozzle from the lance.
5. Clear any obstructions from the nozzle by inserting the cleaning tool.

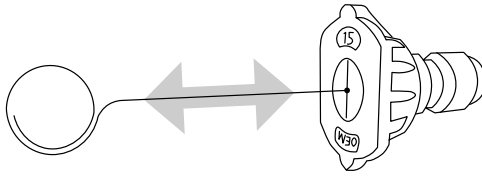

6. Rinse any loose debris from the nozzle by directing a running garden hose into the output of the nozzle for at least 30 seconds.

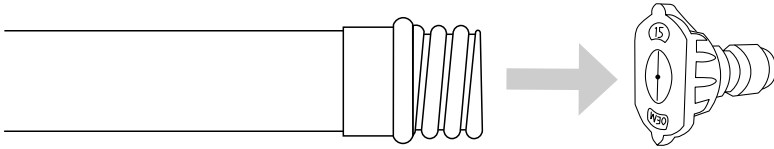

Water Inlet Filter

Before each use, check the inlet filter and clean by following the steps below. Never operate the pressure washer without the inlet filter properly installed.

1. Remove the filter from the pump inlet.
2. Use a water from a running garden hose to clean both sides of the filter.
3. Insert the cleaned filter into the pump inlet with the convex side facing out.

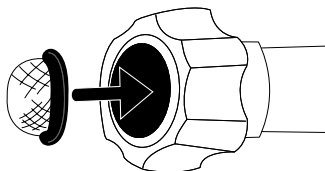

Pump Maintenance

The pump on this unit is a maintenance free design. The pump was filled with oil at the factory and has no oil drain or fill plugs. If there is a problem with the pump on this pressure washer call 1-877-362-4271.

Engine Maintenance

Before each use, check engine for loose or damaged parts, signs of oil or fuel leaks, and/or any other condition that may affect proper operation. Always keep all safety guards in place and in proper working order. Repair or replace all damaged or defective parts immediately.

For safety reasons, the manufacturer recommends all engine service and repairs (including emission control devices and systems) be performed by an authorized service center. All warranty replacements or repairs must be performed by an authorized distribution or service center. To find an authorized service center near you, obtain information about how to make a warranty claim, or to make arrangements for authorized warranty repairs, please call 1-877-362-4271.

For all other information on engine maintenance, refer to the engine manual.

STORAGE AND TRANSPORTATION

Storing for Two Months or Less

1. Fill fuel tank per the OPERATING CHECKLIST section of this manual then add a fuel stabilizer per the manufacturer's recommendations. **NOTE:** Using a fuel stabilizer (sold separately) when storing gasoline may help prevent problems related to alcohol blended fuels in outdoor power equipment engines. Always follow the instructions provided by the fuel stabilizer manufacturer to mix and use correctly.
2. Complete the steps in the OPERATING CHECKLIST, CONNECTING HOSES, and PRIMING THE PUMP sections of this manual.
3. Start the engine per the STARTING section of this manual and run it for ten (10) minutes to allow the stabilized fuel to circulate through the entire fuel system. Be sure to squeeze the trigger to keep water flowing through the pump and spray gun to avoid overheating.
4. Turn the engine switch to the OFF position.
5. Squeeze the spray gun trigger to relieve the pressure in the hose and pump then drain the high pressure hose.
6. Allow the engine to cool completely.
7. Protect the pump by using SIMPSON® Pump Guard per the USING SIMPSON PUMP GUARD section of this manual.
8. Store the pressure washer in a clean, dry area out of direct sunlight.

Storing for More Than Two Months

1. Make sure the engine is completely cool.
 2. Remove all the fuel from fuel tank, fuel lines, and carburetor by loosening the drain screw at the bottom of the carburetor, and draining fuel into an appropriate container.
 3. Change the engine oil.
 4. Remove any dirt and debris from the area around the spark plug, then use a spark plug socket or wrench to remove the spark plug.
 5. Pour .5 ounces (15 ml) of new oil into the engine combustion chamber, then slowly crank the engine by pulling the recoil two (2) times to distribute oil and lubricate the cylinder.
 6. Install the spark plug.
 7. Drain the high-pressure hose.
 8. Protect the pump by using SIMPSON® Pump Guard per the USING SIMPSON PUMP GUARD section of this manual.
 9. Store the pressure washer in a clean, dry area out of direct sunlight.
-

Transportation



WARNING:

TRANSPORTATION

Leaving the pressure washer in an enclosed space where temperatures can rise on a transport vehicle may cause fuel to vaporize and possibly explode. Fire and explosions can cause severe burns and/or death. To avoid leaking or vaporizing fuel, secure the pressure washer in a well ventilated area out of direct sunlight and other heat sources and do not transport the pressure washer on rough roads unless the fuel has been drained beforehand.

1. Turn the engine control switch to the OFF position.
2. To prevent fuel spillage when transporting, keep the pressure washer upright on a level surface.
3. Secure pressure washer with straps or tie downs to prevent tip over and damage from sliding.

NOTE: Do not operate the pressure washer while it is on the transport vehicle.

USING SIMPSON® PUMP GUARD



NOTICE

PUMP DAMAGE

Leaving water inside the pump during freezing weather will cause severe damage to the pump. To avoid costly damage, always treat the pump with SIMPSON® Pump Guard to remove the trapped water and to fill the pump with a lubricating, antifreeze solution.

SIMPSON® Pump Guard (purchase separately) is formulated to protect your pump from freezing damage while lubricating the internal seals. Pump Guard should be used throughout the season to keep the seals pliable and well lubricated. Before storing the unit for winter or for when there is a chance of freezing weather, use pump guard to remove all traces of water from the internal cavities while filling them with an antifreeze solution.

Simply use Pump Guard by following these easy steps:

1. Screw the Pump Guard adapter into the garden hose input on the pump.

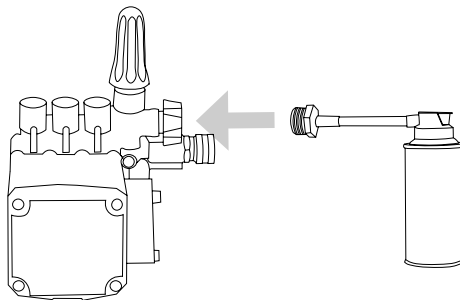

2. Press and hold down on the button until the water and the Pump Guard comes out of the high pressure port.

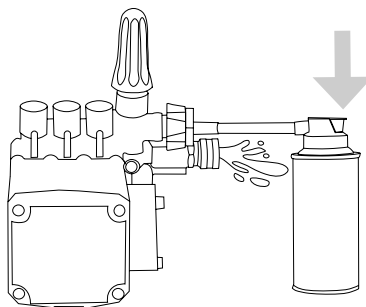

3. Unscrew the Pump Guard from the pump then prepare the pressure washer for storage as outlined in STORAGE AND TRANSPORTATION.

COMMERCIAL LIMITED WARRANTY

WARRANTY COVERAGE TERMS:

The manufacturer of this product agrees to repair or replace designated parts that prove defective within the warranty period listed below at the manufacturer's sole discretion. Specific limitations/extensions and exclusions apply.

This warranty covers defects in material and workmanship and not parts failure due to normal wear, depreciation, abuse, accidental damage, negligence, improper use, maintenance, water quality or storage. To make a claim under the terms of the warranty, all parts said to be defective must be retained and available for return upon request to a designated Warranty Service Center for warranty inspection. The judgments and decisions of the manufacturer concerning the validity of warranty claims are final.

These warranties pass through to the end user and are non-transferable. As a factory authorized and trained Warranty Service Center, the factory will honor the terms of all component warranties and satisfy claims of the appropriate warranty provisions.

This warranty replaces all other warranties, express or implied, including without limitation any warranties of merchantability or fitness for a particular purpose and all such warranties are hereby disclaimed and excluded by the manufacturer. The manufacturer's warranty obligation is limited to repair and replacement of defective products as provided herein and the manufacturer shall not be liable for any further loss, damages, or expenses – including damages from shipping, accident, abuse, acts of God, misuse, or neglect. Neither is damage from repairs using parts not purchased from the manufacturer or alterations performed by non-factory authorized personnel. Failure to install and operate equipment according to the guidelines put forth in the instruction manual shall void warranty.

THIS WARRANTY DOES NOT COVER:

Damage resulting from shipping (claims must be filed with freighter), accident, abuse, act of God, misuse, or neglect. This warranty also does not cover damage from repairs or alterations performed by non-factory authorized personnel or failure to install and operate equipment according to the guidelines put forth in the instruction manual. The manufacturer will not be liable to any persons for consequential damage, for personal injury, or for commercial loss.

RESPONSIBILITY OF ORIGINAL PURCHASER (INITIAL USER):

To process a warranty claim on your SIMPSON® pressure washer, report the concern to 1-877-362-4271 or cservice@fna-group.com for authorization and direction to the nearest authorized service center in your area. Retain original cash register sales receipt as proof of purchase for warranty work. Use reasonable care in the operation and maintenance of the product as described in the Operator's Manual(s).

WHAT THIS WARRANTY DOES NOT COVER:

- Freight damage
- Damage due to chemical deterioration, salt water, rust or corrosion
- Damage caused by parts or accessories not obtained from an authorized dealer or not approved by the manufacturer
- Normal wear of moving parts or components affected by moving parts
- Consumable parts such as: Fuel filter, air filter, spark plug(s), recoil starter rope, oil & lubricant(s).
- Freeze damage.

ENGINE AND EMISSIONS CONTROL SYSTEM

Covered by the engine manufacturer warranty. See engine warranty.

HIGH-PRESSURE PUMP (DEFECTS IN MATERIAL AND WORKMANSHIP)

Five (5) years from date of purchase.

FRAME (DEFECTS IN MATERIAL AND WORKMANSHIP)

Ten (10) years from date of purchase.

ACCESSORIES (DEFECTS IN MATERIAL AND WORKMANSHIP)

Including nozzles, hoses, spray guns, wands, tires, feet

Ninety (90) days from date of purchase.

NOTES

THIS PAGE WAS INTENTIONALLY LEFT BLANK



READ THIS MANUAL CAREFULLY BEFORE OPERATION

Failure to follow the instructions and safety precautions in this manual can result in property damage, serious injury and/or death.

SAVE THIS MANUAL FOR FUTURE REFERENCE