



# WATER TRAILER

## USE AND CARE MANUAL



**NOT FOR SALE IN THE  
STATE OF CALIFORNIA**

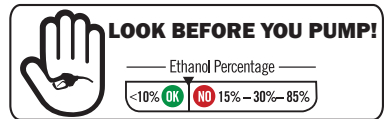
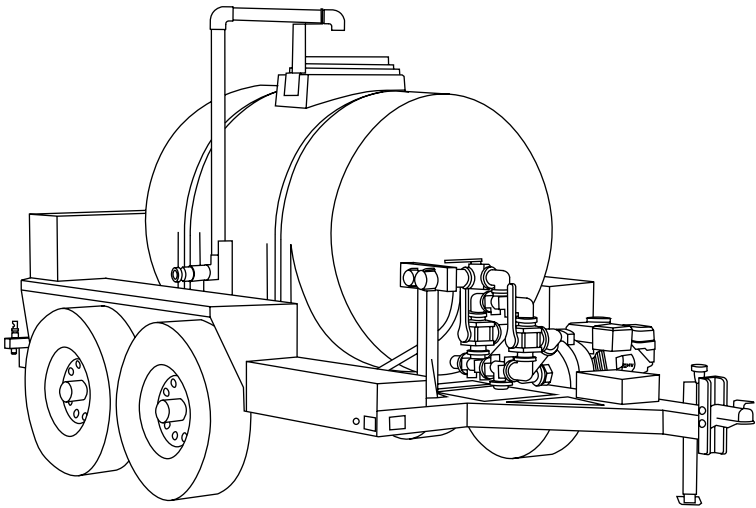

### **READ THIS MANUAL CAREFULLY BEFORE OPERATION**

Failure to follow the instructions and safety precautions in this manual can result in property damage, serious injury and/or death.

If your unit is not working or if there are parts missing or broken, please **DO NOT RETURN IT TO THE PLACE OF PURCHASE**. Contact our Customer Service Department by calling **1-833-362-7368** or emailing **[cservice@fna-group.com](mailto:cservice@fna-group.com)**

### **SAVE THIS MANUAL FOR FUTURE REFERENCE**

**NOTE: Photographs and line drawings used in this manual are for reference only and may not represent your specific model.**

# NOTES

---

---

**THIS PAGE WAS INTENTIONALLY LEFT BLANK**

## SAVE THIS MANUAL FOR FUTURE USE

Keep this manual for future reference. This manual should be considered a permanent part of the product and stay with it. This manual should be available to anyone operating the product(s) it covers. This manual should remain with the product(s) it covers if sold to a new owner. If the manual becomes damaged, lost, or otherwise unusable, you may download a new copy from the product pages at [www.simpsoncleaning.com](http://www.simpsoncleaning.com) or contact customer support by calling 1-833-362-7368.

Write down the model number, serial number, and purchase date of this product in the spaces provided below then keep this manual with the purchase receipt(s) for future reference.

Model Number: \_\_\_\_\_

Serial Number: \_\_\_\_\_

Purchase Date: \_\_\_\_\_



### CALIFORNIA PROPOSITION 65 WARNING

This product and the engine exhaust can expose you to chemicals which are known to the state of California to cause cancer, birth defects, or other reproductive harm. For more information on California Proposition 65, go to [www.P65Warnings.ca.gov](http://www.P65Warnings.ca.gov).



### POLYCYCLIC AROMATIC HYDROCARBON WARNING

The air filter element and air box assembly may contain polycyclic aromatic hydrocarbons (PAHs). Some PAHs may cause cancer. To avoid exposure to PAHs, wear gloves when performing air filter maintenance.

# TABLE OF CONTENTS

---

---

<b>SAFETY INSTRUCTIONS</b>	<b>4</b>
Read this Manual Before Operating	4
Additional Instructions	4
Hazard Alert Symbols	4
<b>DISCLAIMERS</b>	<b>5</b>
<b>PERSONAL PROTECTIVE EQUIPMENT</b>	<b>5</b>
<b>SLIP/TRIP HAZARDS</b>	<b>6</b>
<b>COMPONENT LOCATION</b>	<b>7</b>
<b>SUMMARY OF VALVE LOCATIONS AND POSITIONS</b>	<b>8</b>
<b>MANIFOLD CONNECTIONS</b>	<b>9</b>
<b>DO NOT OPERATE THE PUMP WITH THE VALVES IN THESE POSITIONS</b>	<b>10</b>
<b>PRESSURE FILLING THE TANK</b>	<b>12</b>
<b>VALVE POSITIONS WHEN DISCHARGING FROM TANK</b>	<b>13</b>
Start the Pump in Bypass	13
Using the Discharge Positions	14
Shutting Down: Valve Positions	16
<b>VALVE POSITIONS WHEN SUCTIONING FROM A STANDING WATER SOURCE TO THE TANK</b>	<b>17</b>
<b>TRAILERING SYSTEM</b>	<b>20</b>
Trailer Coupler	20
Adjusting the Trailer Coupler Height	21
Trailer Electrical System	22
Hydraulic Braking System	23

<b>OPERATING CHECKLIST</b>	<b>24</b>
Location	24
High Altitude Operation	24
Operating Conditions	24
Checking the Engine Oil	26
Checking Fuel	27
<b>STARTING THE ENGINE</b>	<b>29</b>
<b>SHUTTING DOWN THE ENGINE</b>	<b>31</b>
<b>TROUBLESHOOTING</b>	<b>31</b>
<b>MAINTENANCE</b>	<b>32</b>
Pump Maintenance	32
Exterior Pump Cleaning	32
Interior Pump Cleaning	33
Engine Maintenance	35
Plumbing Maintenance	35
Trailer Maintenance	35
<b>ENGINE LONG-TERM STORAGE</b>	<b>36</b>
Storing for Two Months or Less	36
Storing for More Than Two Months	36
<b>DRAINING THE SYSTEM FOR STORAGE (WINTERIZE)</b>	<b>37</b>
Draining the System	37
<b>WARRANTY</b>	<b>38</b>

# SAFETY INSTRUCTIONS



## READ THIS MANUAL BEFORE OPERATING

This manual contains important safety information and instructions. **Do not** operate this product until you have read, and completely understand all safety, operation, and maintenance instructions listed in this manual. Failure to follow the information contained in this manual will result in property damage, injury, and/or death.

**NOTE:** The warnings and precautions discussed in this manual cannot cover all conditions and situations that may occur. The operator must understand awareness and caution are factors which cannot be built into this product and so must be exercised by the operator.



## ADDITIONAL INSTRUCTIONS

Along with this manual, be sure to read any additional instructions provided both on and with the product, attached equipment, accessories, and the engine powering the product. Pay careful attention to all additional safety rules and instructions on proper startup, operation, and shutdown procedures. Always use any recommended protective apparel that may be needed to operate the equipment safely.



## HAZARD ALERT SYMBOLS

Be sure to understand the safety symbols and definitions listed below. Each symbol contains one of four words: **DANGER**, **WARNING**, **CAUTION**, **NOTICE**, indicating different levels of hazard severity. These symbols are used throughout this manual and are followed by information about a specific hazard, the consequences of the hazard, and instructions on how to avoid the hazard. Failure to heed these symbols and follow the instructions provided with them will result in property damage, injury, and/or death.

 **DANGER:**

Indicates an imminently dangerous situation, which if not avoided, will result in property damage, serious injury, and/or death.

 **WARNING:**

Indicates a potentially hazardous situation, which if not avoided, could result in property damage, serious injury, and/or death.

 **CAUTION:**

Indicates a hazardous situation, which if not avoided, could result in property damage and/or minor to moderate injury.

**NOTICE**

Indicates information considered important, but not directly hazard related.



## **WARNING:** UNSAFE PRACTICES

Do not operate the unit when fatigued or under the influence of drugs and/or alcohol. Stay alert at all times. Do not overreach or stand on an unstable surface. Do not use while standing on a ladder. Reactive force of the spray will cause hose to kickback and could cause the operator to slip or fall or misdirect the spray. Expect and control this reactive force when using a spray hose. Never point hoses at or spray people and/or animals.

# DISCLAIMERS



All information in this publication was based on the latest product information available at the time of printing. The FNA Group reserves the right to update, change, and/or improve the product and this document at any time, without notice and without incurring any obligation.



This manual may cover more than one machine. The pictures and figures in the manual should be used for reference only. There may be differences between your product and the pictures, drawings and diagrams in this manual.



If you loan, rent or sell this machine, be sure to include all instructional materials with the unit!

## PERSONAL PROTECTIVE EQUIPMENT (PPE)

It is important to understand what personal protective equipment (PPE) should be utilized when using your unit as light or unsecured objects can become hazardous projectiles. Below is a list of PPE items that should be utilized at all times when using the unit.

Hearing - Ear plugs or muffs to protect your hearing.

Vision - ANSI-approved Z87.1 safety glasses or goggles to protect your eyes.

Clothing - Long pants and a long-sleeved shirt to protect your legs and arms from flying debris.

Shoes - Rubber-soled shoes that fully cover your feet to protect against debris, over spray, and electric shock.



### **! WARNING:**

#### **FLUID USAGE**

The SIMPSON Water Trailer is designed to be used only with fresh water, gray water, and brine. Do not pump or transport effluent, black (sewage) water or any types of volatile chemicals. Do not use hot water; use cold water only.



### **! WARNING:**

#### **OPERATING CHECKLIST**

Attempting to start the engine incorrectly or using the unit incorrectly can result in engine and/or pump failure and may cause serious injury or death. To avoid these hazards, be sure to read, understand, and follow the steps outlined in the OPERATING CHECKLIST section of the owner's manual before starting the engine and follow all the guidelines for proper use of the unit.

## **NOTICE**

This appliance is not intended to be used by persons with reduced physical, sensory, or mental capabilities, or lack of experience and knowledge, unless they have been given supervision or instruction concerning use of the appliance by a person responsible for their safety.

Children should be supervised to ensure that they do not use or play with the appliance.

## CAUTION



## TRIPPING HAZARD

Hoses may pose a tripping hazard that can cause injuries resulting from a fall

## CAUTION:

## SLIP / TRIP HAZARDS

When spraying in public areas, signs should be posted that indicate to stay clear of the area as spraying is being performed. Also, signs should be posted that the surface may be slippery and trip hazards may be present.

Special consideration needs to be made to the safety of not just the operator of the unit, but also people who may be adjacent to the area being cleaned. The best way to warn unsuspecting individuals is with signage and barriers.

Barriers can be as simple as plastic traffic cones or barricades to using barrier belts around the area being sprayed. Remember, spraying can dislodge weak or broken pavement, turning it into projectiles that may injure others. Keeping people clear of the area is the best way to avoid injury.

Wet pavement can be slippery to unsuspecting individuals causing injury from slips and falls. Hoses can be trip hazards. Segregating the area and placing appropriate signage can reduce injury.

### Sign examples



### Barrier examples

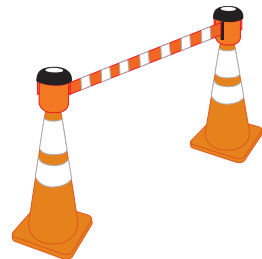



# COMPONENT LOCATION

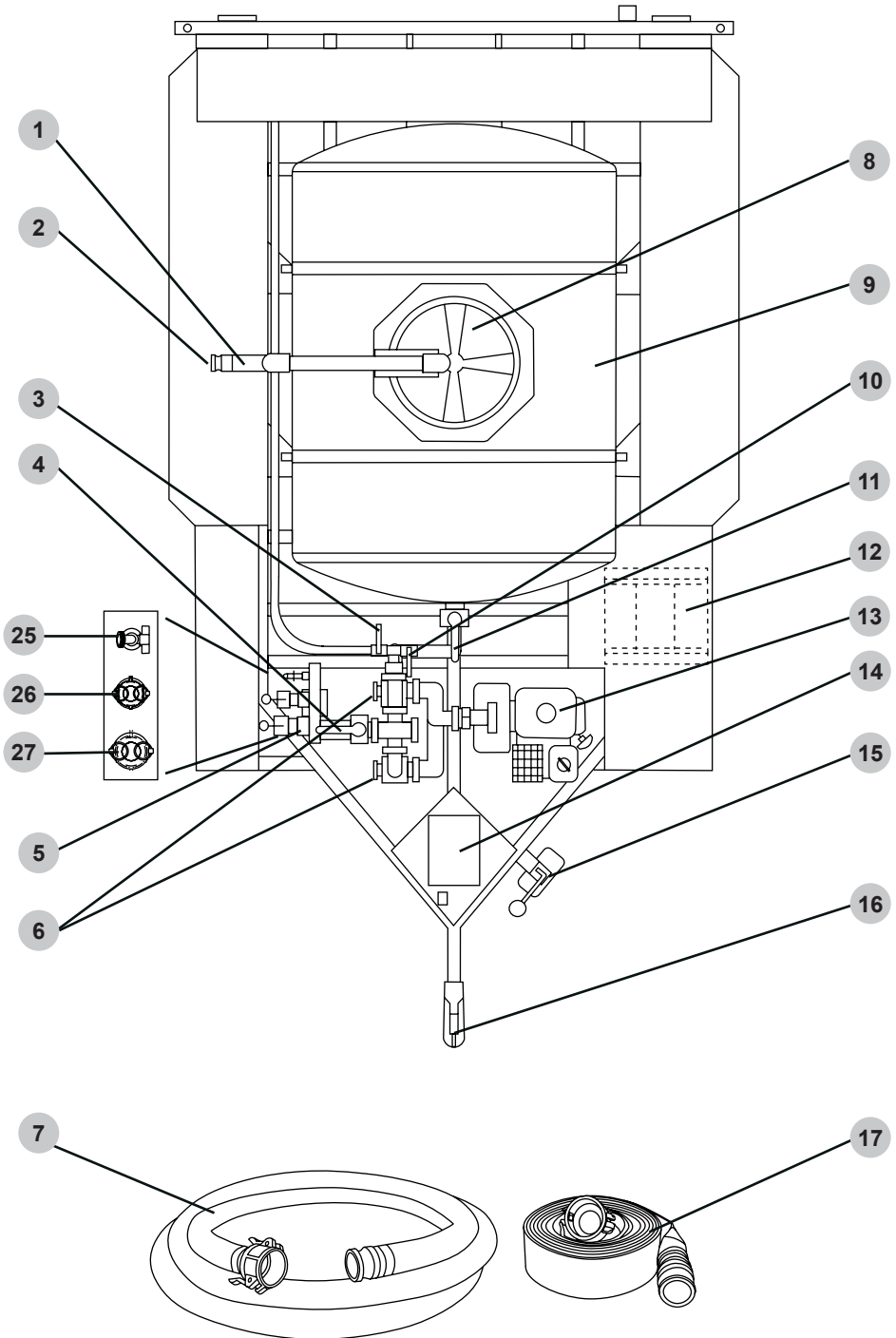

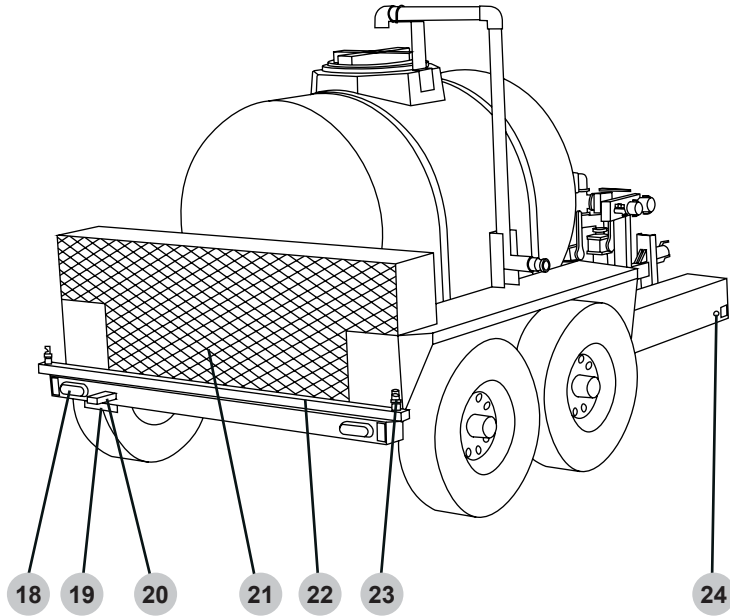

- |   |  |
|---|--|
| 1. Pressure fill pipe   | 15. Trailer jack.                        |
| 2. Pressure fill pipe 2" hose connector                                       | 16. Trailer coupler                      |
| 3. SPRAY BAR valve  | 17. 50ft (15.2M) lay flat discharge hose |
| 4. MANIFOLD valve   | 18. Red turn/brake light x 2             |
| 5. Manifold   | 19. License plate holder                 |
| 6. FLOW valves  | 20. License plate light                  |
| 7. 20ft (6.1M) Suction rated hose   | 21. Hose storage bin                     |
| 8. Vented tank cover  | 22. Spray bar assembly                   |
| 9. Tank   | 23. Spray nozzle (one of two)            |
| 10. HOSE REEL valve (optional)  | 24. Amber marker light                   |
| 11. TANK valve and outlet (Fig. 9)  | 25. Manifold 3/4" garden HOSE BIBB       |
| 12. Hose reel (optional)  | 26. Manifold 1.5" HOSE connector         |
| 13. Engine-powered pump   | 27. Manifold 2" HOSE connector           |
| 14. Poly box for electrical components including the breakaway system control |  |

**NOTE: Photographs and line drawings used in this manual are for reference only and may not represent your specific model.**

# SUMMARY OF VALVE LOCATIONS AND POSITIONS

**Fig. 1: Bird's Eye View of Plumbing**

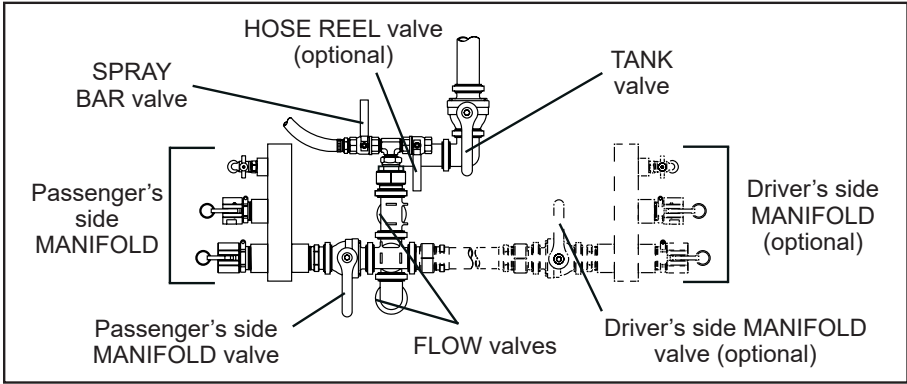

**Fig. 2: MANIFOLD, TANK, SPRAY BAR, and HOSE REEL Valves**

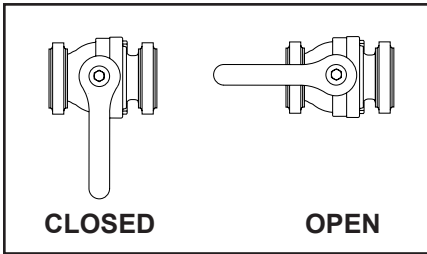

**Fig. 3: HOSE BIBB**

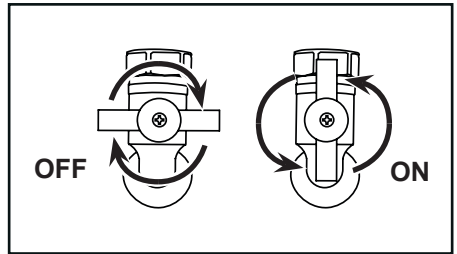

**Fig. 4: Side View of FLOW Valves**

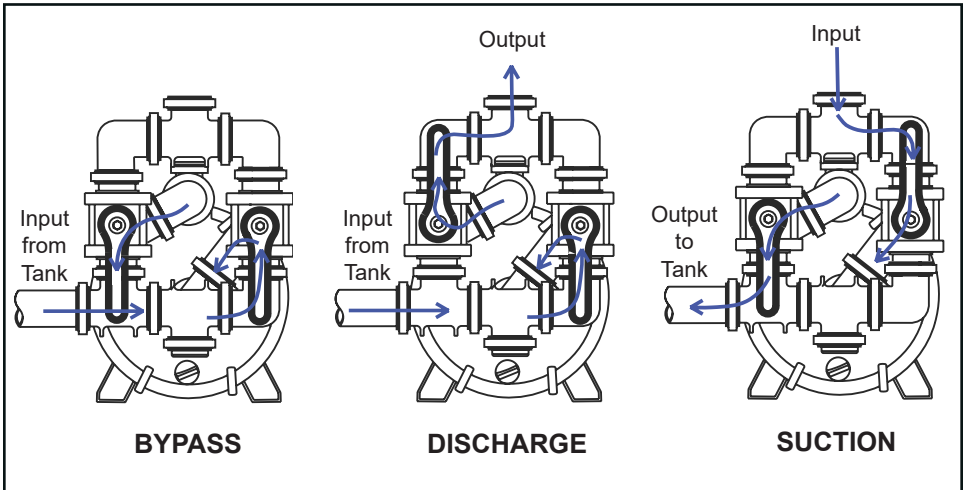

# MANIFOLD CONNECTIONS

The manifold allows you to discharge water from the tank out to a hose (for example, irrigation) or to use a hose to suction water into the tank (1.5 or 2" only).

The manifold assembly contains a 1.5" HOSE connection, a 2" HOSE connection and a standard 3/4" garden HOSE BIBB (see Fig. 5).

The 1.5" and 2" HOSE connectors have cam lever dust covers (Fig. 6) that are chained to the manifold for retention. Always have the HOSE CAMS in place and locked before moving the trailer. Loose HOSE CAMS may come free at highway speeds, leading to injury.

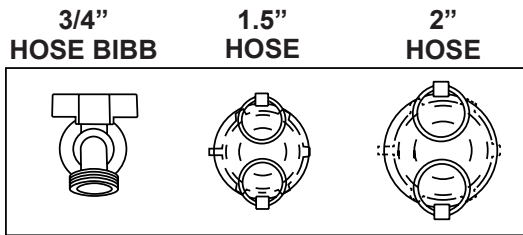

Fig. 5

## HOSE CAM:

Place the cover on the hose connector then rotate the cams to lock the cover onto the connector.

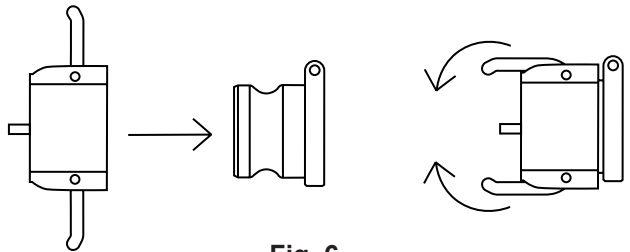

Fig. 6



**CAUTION:**

**PUMP DAMAGE**

When pumping from a standing source using the manifold, only use the 1.5" or 2" hose connections. The 3/4" hose bibb is too restrictive and could damage the pump due to insufficient water flow.

**WARNING:**

**DUST COVERS**

Always have the dust covers in place and locked before moving the trailer. Loose covers may come free at highway speeds leading to injury. Make it a point each time you will be moving the trailer to inspect the dust covers and verify they are properly locked.

# DO NOT OPERATE THE PUMP WITH THE VALVES IN THESE POSITIONS

---

---

There are operating modes that could be harmful to your pump. It is important to never run the pump dry as pump damage may occur. It is also important to provide proper water movement throughout the manifold. To ensure proper pump operation, NEVER operate the water trailer pump in these following combinations:

- Both FLOW valve handles are pointed upwards (Fig. 7).

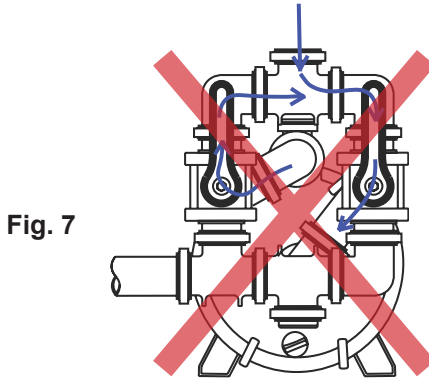

Fig. 7

- The FLOW valves are set to the SUCTION position (Fig. 1 and 4) and the SPRAY BAR valve is OPEN (Fig. 1 and 2).
- The FLOW valves are set to the SUCTION position (Fig. 1 and 4) and a MANIFOLD valve is both OPEN and DISCONNECTED (Fig. 1 and 2).
- The FLOW valves are set to the DISCHARGE position (Fig. 1 and 4) and the TANK valve is CLOSED (Fig. 1 and 2).
- If intending to use the spray bar, the FLOW valves are set to the DISCHARGE position (Fig. 1 and 4) and the SPRAY BAR valve is CLOSED (Fig. 1 and 2).
- If intending to use the hose reel, the FLOW valves are set to the DISCHARGE position (Fig. 1 and 4) and the HOSE REEL valve is CLOSED (Fig. 1 and 2).
- If intending to use the MANIFOLD valve, the FLOW valves are set to the DISCHARGE position (Fig. 1 and 4) and the MANIFOLD valve is CLOSED (Fig. 1 and 2).
- The FLOW valves are set to the BYPASS position (Fig. 1 and 4) and the TANK valve is CLOSED (Fig. 1 and 2).

# PRESSURE FILLING THE TANK

## **! CAUTION:** TRAILER MOVEMENT

Whenever the trailer is disconnected from the tow vehicle, the trailer should be parked on a level surface and with the wheels chocked (not included). Trailers with non-chocked wheels can roll when parked on non-level pavement or when accidentally bumped from another vehicle leading to injury/death and property damage.

The tank can be filled from a pressurized water source by using the 2" tank fill on the passenger's side of the trailer. The SIMPSON Water Trailer is designed to be used only with fresh water, gray water, and brine. Do not pump or transport effluent, black (sewage) water or any types of volatile chemicals.

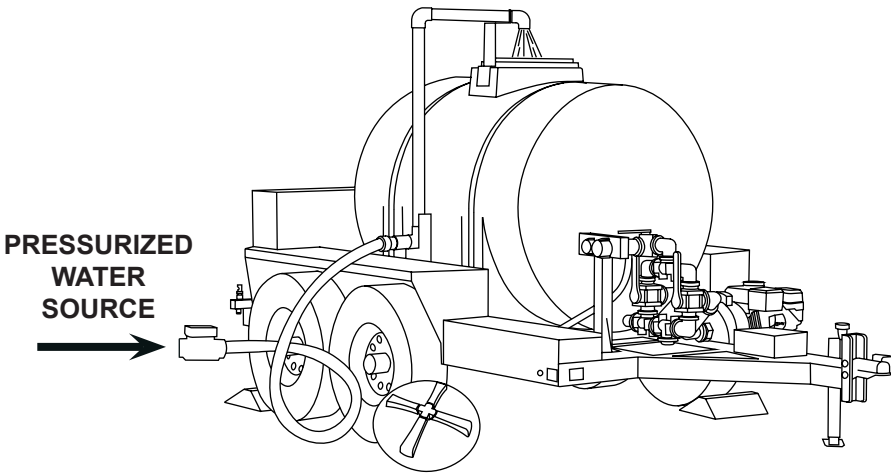

1. Remove the cover of the tank.
2. Connect a 2" hose from the pressurized water source to the fill connector.
3. Turn on the water source allowing the tank to fill to the required level.
4. Turn off the water source then disconnect the hose from the fill pipe.
5. Place the cover back onto the tank, secure.

# VALVE POSITIONS WHEN DISCHARGING FROM TANK

Make sure to read and understand the DO NOT OPERATE THE PUMP WITH THE VALVES IN THESE POSITIONS section before proceeding. Make sure to follow the steps outlined in this chapter (VALVE POSITIONS WHEN DISCHARGING FROM TANK) to ensure the pump and all the valve handles are in the proper orientation. It is important to read this chapter before starting, during operation, and upon shutting off the engine.



## **! WARNING:**

### **OPERATING CHECKLIST**

Attempting to start the engine incorrectly can result in engine and/or pump damage, and may cause serious injury or death. To avoid these hazards, be sure to read, understand, and follow the steps outlined in the OPERATING CHECKLIST section of the owner's manual before starting the engine, and follow all the guidelines for proper use of the SIMPSON Water Trailer.



## **NOTICE**

### **PUMP PRIMING**

This pump will not prime when dry. Running the pump dry without priming can damage the pump assembly and seals. Damage caused by running dry is not covered by warranty. To avoid damaging the seals and pump assembly, do not run the pump when it is dry without priming.

## **1. START THE PUMP IN BYPASS**

## **! CAUTION:**

### **PUMP DAMAGE**

Failure to properly set the valves can cause damage to the pump and the piping. Always set the valves and verify the pump is properly primed before starting the engine.

1. Make sure the engine is OFF.
2. Move the FLOW valves to the BYPASS position (Fig. 1 and 4). This will run the pump in a loop, allowing the engine to be started without having an output or input hose.
3. Move the TANK valve to OPEN (Figs. 1-2).
4. Move the MANIFOLD valve, HOSE REEL valve, and SPRAY BAR valve to CLOSED (Figs. 1-2).

5. Ensure the pump is primed. If you start to remove the primer cover and water begins to flow out, it is primed. If not, remove the cover and fill the pump with water (Fig. 8). Thread the cover back onto the funnel; tighten.

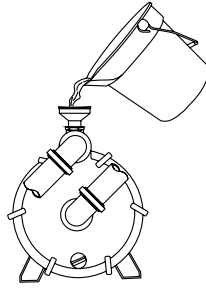

Fig. 8



## **NOTICE**

### **PUMP PRIMING**

This pump will not prime when dry. Running the pump dry without priming can damage the pump assembly and seals. Damage caused by running dry is not covered by warranty. To avoid damaging the seals and pump assembly, do not run the pump when it is dry without priming.

6. Using the STARTING THE ENGINE instructions, start the engine of the pump.

**NOTE:** Complete the steps in the OPERATING CHECKLIST section of this manual before starting the engine. Failure to do so could cause damage to the engine. If needed, refer to your Engine Owner's Manual for specific starting instructions.



## **NOTICE**

### **PUMP DAMAGE**

Running the engine for more than two minutes in the BYPASS position will overheat the pump and possibly cause damage. To avoid overheating the pump, shut off the engine if being used for longer than two minutes.

## **2. USING THE DISCHARGE POSITIONS**

When needing to discharge water through the manifold or discharge water through the spray bar, follow the appropriate subsection 2A, 2B, or 2C. After following the appropriate subsection, you may switch to a different subsection or move to the final step, SHUTTING DOWN: VALVE POSITIONS. It is important to always start the pump in bypass according to the previous section (START THE PUMP IN BYPASS) before proceeding to this section.

### **2A. DISCHARGE (MANIFOLD)**

The manifold connections can be used for a variety of watering uses. As talked about in MANIFOLD CONNECTIONS, you connect a standard 3/4" garden hose, a 1.5" hose, or a 2" hose as the output. In order to use these outputs, make sure the tank is completely filled or has enough water for your application. Do not allow the pump to go dry as damage may occur.



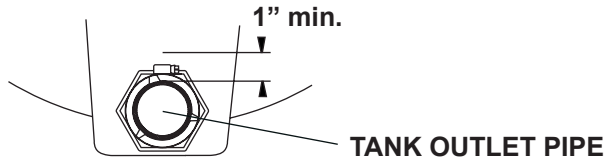

Fig. 9



**! CAUTION:**

**PUMP DAMAGE**

Never allow the tank water level to fall below a level of one inch above the outlet pipe of the tank (Fig. 9). If the tank fully drains, pump damage may occur from lack of water and you will only be able to refill the tank from a pressurized water source.

1. Follow all steps outlined in START THE PUMP IN BYPASS before proceeding.
2. Connect a hose to the appropriate manifold connection (1.5", 2" or 3/4" garden hose)(Fig. 5). If using a 3/4" garden hose, rotate the HOSE BIBB handle counter-clockwise to ON (Fig. 3).
3. Move the MANIFOLD valve to OPEN (Figs. 1-2).
4. Slowly move the FLOW valves to the DISCHARGE position (Fig. 1 and 4).
5. Use the output until your application is completed or you have met the minimum allowed amount of water in the tank. DO NOT allow the tank to pump dry.
6. Slowly move the FLOW valves to the BYPASS position (Fig. 1 and 4).
7. Move the MANIFOLD valve to CLOSED (Figs. 1-2).
8. Disconnect the hose. Place the HOSE CAM on the hose connection and lock into place (Fig. 6), -or- rotate the HOSE BIBB handle clockwise to OFF (Fig. 3).
9. Follow subsections 2A, 2B, or 2C as needed, or proceed to the SHUTTING DOWN section.

**OR**

## 2B. DISCHARGE (SPRAY BAR)

The spray bar allows you to water down areas for dust reduction as well as washing the pavement of loose dirt and debris. In order to use the spray bar, make sure the tank is fully filled or has enough water for your application. Do not allow the pump to go dry as damage may occur.

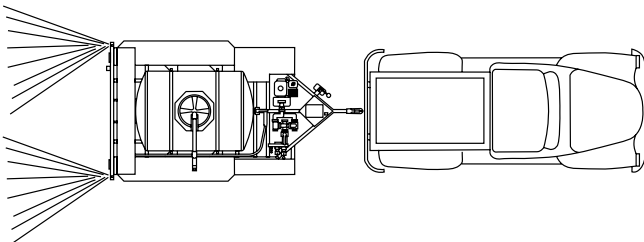



**CAUTION:**

**PUMP DAMAGE**

Never allow the tank water level to fall below a level of one inch above the outlet pipe of the tank (Fig. 9). If the tank fully drains, pump damage may occur from lack of water and you will only be able to refill the tank from a pressurized water source.

1. Follow all steps outlined in START THE PUMP IN BYPASS before proceeding.
2. Move the SPRAY BAR valve to OPEN (Figs. 1-2).
3. Slowly move the FLOW valves to the DISCHARGE position (Fig. 1 and 4).
4. Use the output until your application is completed or you have met the minimum allowed amount of water in the tank. DO NOT allow the tank to pump dry.
5. Slowly move the FLOW valves to the BYPASS position (Fig. 1 and 4).
6. Move the SPRAY BAR valve to CLOSED (Figs. 1-2)
7. Follow subsections 2A, 2B, or 2C as needed, or proceed to the SHUTTING DOWN section.

**OR**

## **2C. DISCHARGE (HOSE REEL) (if equipped)**

The hose reel is an optional accessory that would allow you to use a hose that is mounted on the driver's side of the trailer. In order to use the hose reel, make sure the tank is fully filled or has enough water for your application. Do not allow the pump to go dry as damage may occur.



**CAUTION:**

**PUMP DAMAGE**

Never allow the tank water level to fall below a level of one inch above the outlet pipe of the tank (Fig. 7). If the tank fully drains, pump damage may occur from lack of water and you will only be able to refill the tank from a pressurized water source.

1. Follow all steps outlined in START THE PUMP IN BYPASS before proceeding.
2. Move the HOSE REEL valve to OPEN (Figs. 1-2).
3. Slowly move the FLOW valves to the DISCHARGE position (Fig. 1 and 4).
4. Use the output until your application is completed or you have met the minimum allowed amount of water in the tank. DO NOT allow the tank to pump dry.
5. Slowly move the FLOW valves to the BYPASS position (Fig. 1 and 4).
6. Move the HOSE REEL valve to CLOSED (Figs. 1-2).
7. Follow subsections 2A, 2B, or 2C as needed, or proceed to the SHUTTING DOWN section.

## **3. SHUTTING DOWN**

1. Shut off the engine by using the SHUTTING DOWN THE ENGINE instructions.
2. Move the TANK valve to CLOSED (Figs. 1-2).

# VALVE POSITIONS WHEN SUCTIONING FROM A STANDING WATER SOURCE TO THE TANK

Make sure to read and understand the DO NOT OPERATE THE PUMP WITH THE VALVES IN THESE POSITIONS section before proceeding. Make sure to follow the steps outlined in this chapter (VALVE POSITIONS WHEN SUCTIONING FROM A STANDING WATER SOURCE TO THE TANK) to ensure the pump and all the valve handles are in the proper orientation. It is important to read this chapter before starting, during operation, and upon shutting off the engine.



## WARNING:

### OPERATING CHECKLIST

Attempting to start the engine incorrectly can result in engine and/or pump damage, and may cause serious injury or death. To avoid these hazards, be sure to read, understand, and follow the steps outlined in the OPERATING CHECKLIST section of the owner's manual before starting the engine, and follow all the guidelines for proper use of the SIMPSON Water Trailer.



## NOTICE

### PUMP PRIMING

This pump will not prime when dry. Running the pump dry without priming can damage the pump assembly and seals. Damage caused by running dry is not covered by warranty. To avoid damaging the seals and pump assembly, do not run the pump when it is dry without priming.



## CAUTION:

### TRAILER MOVEMENT

Whenever the trailer is disconnected from the tow vehicle, the trailer should be parked on a level surface with the wheels chocked (not included). Trailers with non-chocked wheels can roll when parked on non-level pavement or when accidentally bumped from another vehicle leading to injury/death and property damage.

Besides filling the tank from a pressurized sources of water, you also have the ability to fill the tank from a standing source of water such as a lake, stream or pond (Fig. 26). In order to do this, you will need to use the 2" rigid suction hose and the on-board pump. We recommend using a strainer / filter (not included) on the suction hose.

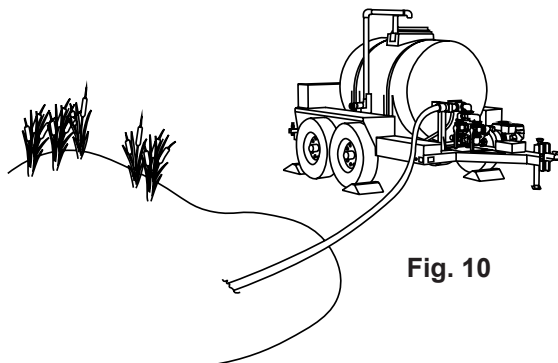

Fig. 10

1. Make sure the engine is OFF.
2. Make sure the SPRAY BAR valve and HOSE REEL valve are in the CLOSED position (Figs. 1-2).
3. Make sure the TANK valve and MANIFOLD valve are in the OPEN position (Figs. 1-2).
4. Move the FLOW valves to the SUCTION position (Fig. 1-4).
5. Place a filter / strainer (not included) onto the end of the rigid suction hose (Fig. 11), before placing the hose into the water. *NOTE:* The total lift from the filter / strainer to the level of the manifold must not exceed 25 feet (7.6 meters).

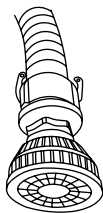

Fig. 11



## **NOTICE**

### **PUMP DAMAGE**

We recommended having a filter (not included) on the end of the suction hose. Not using a filter can introduce debris into the pump and the tank that may cause damage. Always place the filter at a depth where air cannot be introduced into the system, but do not allow it to sit on the muddy bottom of the source.

6. Connect the other end of the hose to the 2" HOSE connection (Fig. 5). Make sure the 3/4" HOSE BIBB is OFF (Fig. 3 and 5) and the 1.5" HOSE connection is CLOSED (Fig. 5).
7. Remove the cover and fill the pump with water (Fig. 12). Thread the cover back onto the funnel; tighten.

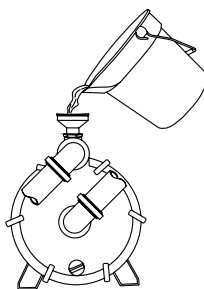

Fig. 12



## **NOTICE**

### **PUMP PRIMING**

This pump will not prime when dry. Running the pump dry without priming can damage the pump assembly and seals. Damage caused by running dry is not covered by warranty. To avoid damaging the seals and pump assembly, do not run the pump when it is dry without priming.

8. Using the STARTING THE ENGINE instructions, start the engine of the pump. If air begins to discharge, immediately shut off the engine by using the SHUTTING DOWN THE ENGINE instructions.
9. Repeat steps 6-7 until only water is being discharged into the tank.
10. Fill the tank.
11. Once the tank is filled, shut off the engine by using the SHUTTING DOWN THE ENGINE instructions.
12. Move the TANK valve and MANIFOLD valve to CLOSED (Figs. 1-2).
13. Disconnect the hose. Place the HOSE CAM on the hose connection; lock into place (Fig. 6).

# TRAILERING SYSTEM

## **! CAUTION:**

### TRAILER MOVEMENT

Whenever the trailer is disconnected from the tow vehicle, the trailer should be parked on a level surface and with the wheels chocked (not included). Trailers with non-chocked wheels can roll when parked on non-level pavement or when accidentally bumped from another vehicle leading to injury/death and property damage.

## TRAILER COUPLER

The trailer coupler of the SIMPSON Water Trailer is adjustable in height. It is important to keep the trailer as level as possible with the tow vehicle. This is accomplished by raising or lowering the coupler within the channel.

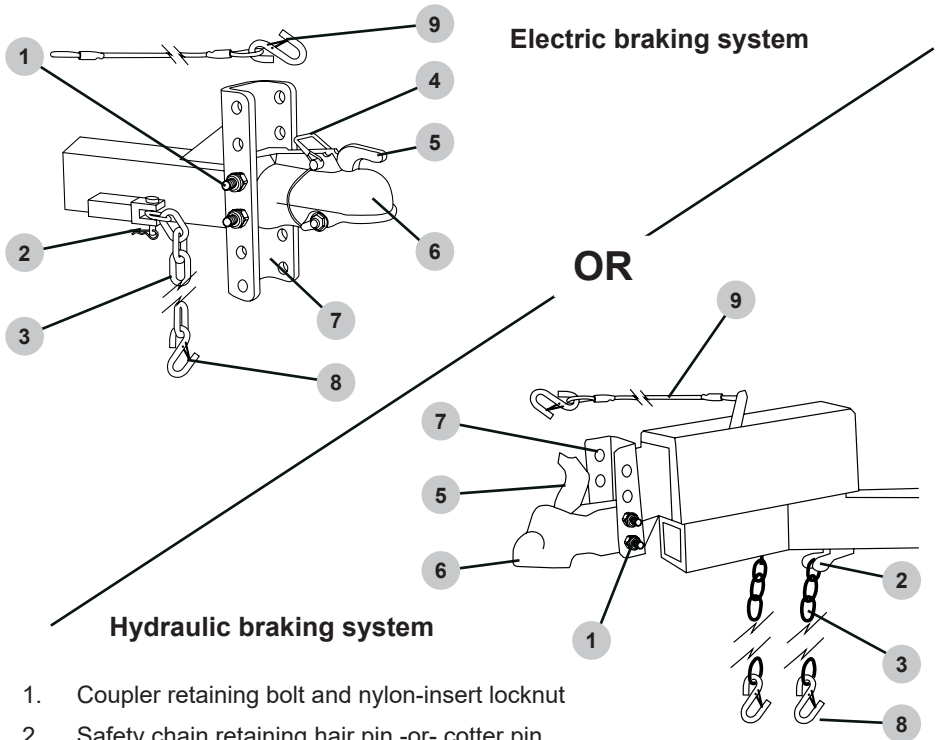

1. Coupler retaining bolt and nylon-insert locknut
2. Safety chain retaining hair pin -or- cotter pin
3. Safety chain assembly
4. Safety pin and lanyard
5. Latch
6. Coupler
7. Coupler channel
8. Snap hook
9. Brake breakaway cable assembly

## **NOTICE**

When the trailer was ordered, you should have picked the coupler that matched your hitch. If you did not specify a coupler or did not receive one, please contact our Customer Service Department by calling 1-833-362-7368 or emailing [cservice@fna-group.com](mailto:cservice@fna-group.com)

## **WARNING:**

## **MATCHING TRAILER AND HITCH**

The use of a hitch with a load rating less than the load rating of the trailer can result in loss of control and may lead to death or injury. Using a tow vehicle with a towing capacity lower than the load rating of the trailer can result in loss of control and may result in injury or death. Be sure your hitch and tow vehicle are rated for the Gross Vehicle Weight Rating (GVWR) of your trailer.

## **WARNING:**

## **LOAD DISTRIBUTION**

Improper front / rear load distribution can lead to poor trailer sway stability or poor tow vehicle handling. The water trailer has been designed to have the proper tongue weight regardless of the tank being empty or full. Adding items or storing items in or on the trailer may exceed GVWR of the axles and GTW which will change the tongue weight distribution and cause an unsafe traveling condition. **DO NOT** modify or add to the trailer.

## **ADJUSTING THE TRAILER COUPLER HEIGHT**

1. With the trailer on level pavement and the tank empty, connect the trailer to the tow vehicle; raise the jack.
2. Place a spirit level on the tongue behind the coupler channel (Fig. 13).

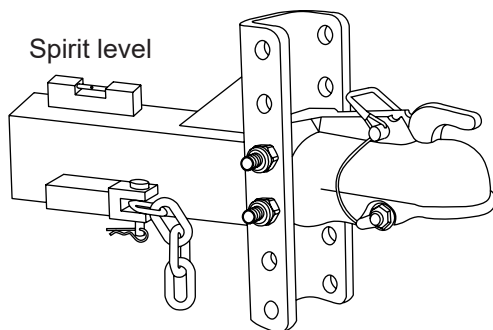

**Fig. 13**

3. The trailer should be as level as possible with the tow vehicle. If it is not, go to step 4.
4. Lower the jack to allow the tow vehicle to be moved away from the trailer.
5. Using two open end wrenches, loosen the coupler retaining bolts. Remove the nuts.
6. If the spirit level bubble was toward the vehicle (Fig. 14), the coupler is set too low. If the bubble was toward the trailer, the coupler is set too high.
7. While holding the coupler with one hand, remove the bolts being careful not to allow the coupler to fall to the ground.
8. Raise or lower the coupler as required to level the trailer to the tow vehicle.

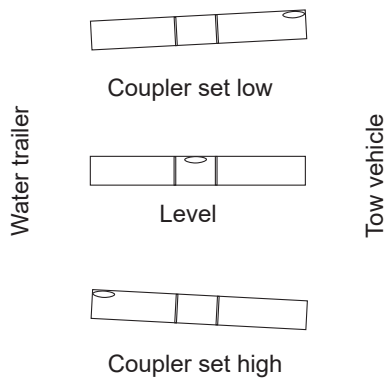
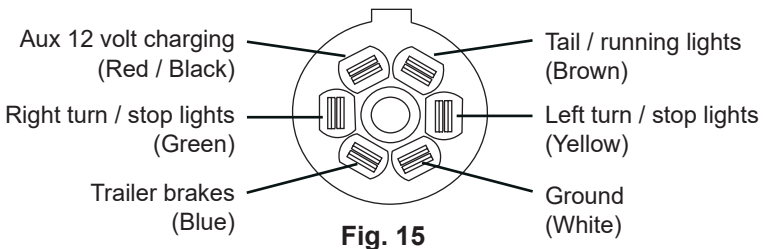

**Fig. 14**

9. Insert the bolts then hand thread the nuts until snug. Do not fully tighten.
10. Once again connect the tow vehicle and rise the jack.
11. Using the spirit level, check for level by placing it on the tongue.
12. If the trailer is now level to the tow vehicle, lower the jack to release pressure off of the coupler.
13. Using open end wrenches, tighten the nuts.
14. If the trailer was not level in Step 12, repeats Steps 4 through 12 until it is. Once the level as been made as close as possible, tighten the nuts as outlined in Step 13.

## TRAILER ELECTRICAL SYSTEM

The SIMPSON Water Trailer is equipped with an electrical braking system as well as an emergency break-away braking system. The tow vehicle must be equipped with the appropriate receptacle for proper operation. If equipped with electric brakes, a seven pin trailer receptacle must be wired to the SAE J2863 standard (Fig. 15). If equipped with hydraulic brakes, a 4-way flat trailer socket must be wired to the 4-way flat trailer connector (Fig. 16).





The controls and battery for the break-away braking system are located within the poly box (Fig. 17) behind the trailer tongue. The battery is charged by the tow vehicle but should be checked periodically and after long-term storage of the trailer. The charge status of the battery can be determined by pushing the test button (Fig. 18).

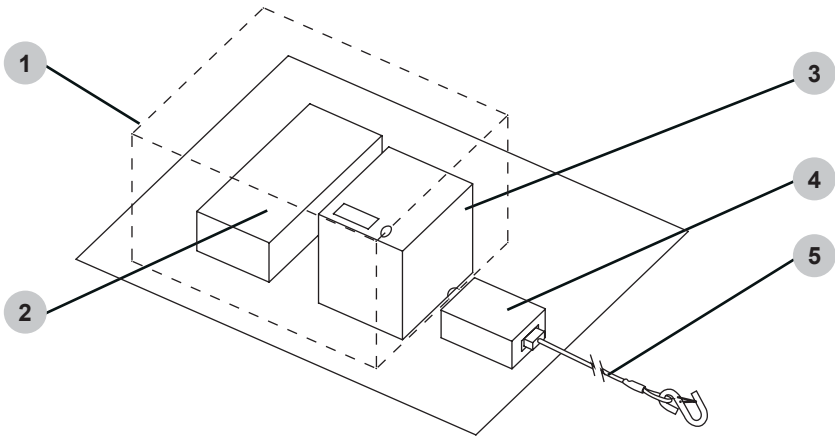

**Fig. 17**

1. Poly box.
2. Wiring harness junction box.
3. Break-away controller and battery.
4. Break-away switch.
5. Break-away cable.

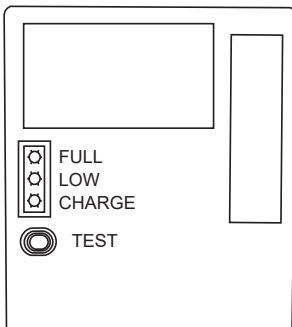

**Fig. 18**

To test the battery, press the TEST button on the controller housing. A green LED indicates the battery is fully charged. A red LED indicates the battery must be charged before the trailer is used. A steady yellow LED indicates the trailer is connected to the tow vehicle and the battery is being charged.

The battery should be fully charged before each use of the trailer. **NOTE:** A discharged or low battery will not operated the brakes in a break-away situation.

When trailering, you must secure the break-away cable to the tow vehicle for the system to operate correctly in the situation of a break-away trailer.

## HYDRAULIC BRAKING SYSTEM (optional)

Please refer to DEMCO manual BH20022 for important safety, maintenance and usage instructions.

# OPERATING CHECKLIST

## Location

Being that this is a trailer based device, it is understood that the trailer could be used in many different locations. Never operate the gasoline powered pump inside any structure or close to any structure. Fumes can easily enter the structure causing carbon monoxide poisoning.



**! WARNING:**

**TOXIC FUMES**

Engine exhaust contains carbon monoxide, an odorless, colorless, poisonous gas. Running an engine indoors will kill you in minutes. Never use this product inside a garage or any other kind of enclosure even if doors and windows are open. Run engine outside at least 20 feet (6 meters) away from windows, doors, and vents. Carefully consider wind direction and air currents when using this product outside to avoid breathing in engine exhaust. Always use a carbon monoxide detector in any occupied buildings near the running engine.

## High Altitude Operation

This engine will have proper engine performance and emission control when it is operated at or below an altitude of 5000 feet (1524 meters). This engine requires a high-altitude carburetor kit to ensure proper engine performance and emission control when operated at altitudes above 5000 feet (1524 meters). Operating the machine with the wrong engine configuration above 5000 feet (1524 meters) may increase its emissions, decrease fuel efficiency, and hurt performance. To obtain a high altitude carburetor kit, contact your nearest authorized service center.



**NOTICE**

**ALTITUDE**

Operating the engine with a high-altitude carburetor jet kit at an altitude below 5000 feet (1524 meters) will cause the engine to run too hot. Overheating the engine could result in serious engine damage. To avoid this hazard, make sure the correct carburetor kit is installed and the air/fuel mixture is set correctly for your altitude.

## Operating Conditions

Before each use, check for loose or damaged parts, leaks, and/or any other condition that may affect proper operation. Repair or replace all damaged and/or defective parts with authorized parts immediately. Do not operate the machine with missing, broken, or unauthorized parts. Always keep all safety guards in place and in proper working order. For safety reasons, the manufacturer recommends all maintenance and repairs be performed by an authorized service center.

Before starting the engine, remove any excessive dirt and debris from cooling vents, exhaust, and starter recoil areas. If you have questions about the proper use of your pump, please contact customer support at 1-833-362-7368 or [cservice@fna-group.com](mailto:cservice@fna-group.com).

**! WARNING:****CHILDREN AND UNTRAINED ADULTS**

Do not allow children or untrained adults to operate or play with the appliance as they can be seriously injured or killed. Anyone operating the appliance should receive proper instructions, understand safe operation, and thoroughly read the owner's manual before operating this product. Keep children and pets away from the appliance while it is in operation. Always turn off the engine before leaving the area.

**! WARNING:****INSPECT BEFORE OPERATING**

Failure to inspect this product before use could create a hazardous situation resulting in product damage, serious injury, and/or death. To avoid these hazards, inspect the trailer before each use. Check for loose or damaged parts, signs of oil or fuel leaks, missing guards, plugged cooling vents, or any other condition that may affect proper operation. Repair or replace all damaged or defective parts with authorized parts and keep all safety guards in place and in proper working order before using the trailer.

**! CAUTION:****HOT SURFACES**

A running engine produces heat. The surfaces of the engine, other related components, and engine exhaust gas can get hot enough to cause moderate burns or ignite materials on contact (such as siding, plastic, rubber, vinyl, or hoses). To avoid burns, do not touch engine surfaces or exhaust gases while operating and allow engine to cool completely before moving, touching, or performing any maintenance. To avoid a fire, keep all flammable materials at least five feet away from all sides of the engine. Do not store extra fuel on the trailer. Never cover the engine during operation or directly after being used.

**! WARNING:****MOVING PARTS**

This product has many parts that move at high speeds. Moving parts can cause crushing injuries, broken bones, severe lacerations, and/or traumatic amputations. To prevent injury, never place fingers, hands, feet, or other body parts near running engine. Never operate product with covers, shrouds, or other guards removed. Do not wear loose-fitting clothing, dangling drawstrings, or any other hanging items that could become entangled in moving parts while operating. Tie up long hair and remove jewelry before operating.

**! DANGER:****ELECTRICAL SHOCK**

Spray directed at electrical receptacles or switches, or objects connected to an electrical circuit, could result in a fatal electrical shock. Direct spray away from electric receptacles, switches and equipment. Never clean any electrically operated device, even when disconnected, unless it clearly states in its manual that such cleaning is approved.

**! DANGER:****RISK OF EXPLOSION OR FIRE**

Operating the engine in an explosive environment could result in a fire. Operate and fuel equipment in well-ventilated areas free from obstructions. Equip areas with fire extinguisher suitable for gasoline fires.

## Checking the Engine Oil



**CAUTION:**

**HOT OIL**

Hot oil can cause serious burns. To prevent getting burned when changing or checking the engine oil, wear gloves and change the oil when the engine is warm but not hot.



**NOTICE**

**LOW OIL SENSOR**

The low oil sensor (if equipped) will automatically stop the engine when the oil level falls below the safe limit. To avoid an unexpected shutdown, check the oil level regularly, fill to the upper limit, and always operate engine on a level surface.



**NOTICE**

**FILL ENGINE BEFORE USE**

The engine is shipped from the factory without oil. Running the engine without oil will result in severe engine damage and void the warranty. To avoid causing engine damage and voiding the warranty, fill the engine with the recommended oil type before starting.



**NOTICE**

**USE CORRECT ENGINE OIL**

Oil is a major factor in the performance and service life of any engine. Using the incorrect oil may damage the engine and void the warranty. To avoid causing engine damage and voiding the warranty, check and change oil as required using the correct engine oil.

1. Check the oil with the trailer on level pavement.
2. Unscrew the engine oil dipstick (Fig. 19), remove it and wipe the dipstick clean.
3. Place the dipstick into the filler neck leaving it to rest on the lip; do not thread in.
4. Remove the dipstick from the filler neck then check the oil level. Oil level should be at the upper oil limit on the dipstick (Fig. 20).
5. If the level is low, add the recommended oil to the crankcase until the level reaches the upper limit of the dipstick. Do not overfill. See Engine Owner's Manual for the recommended oil.
6. Thread in the dipstick, hand tighten.

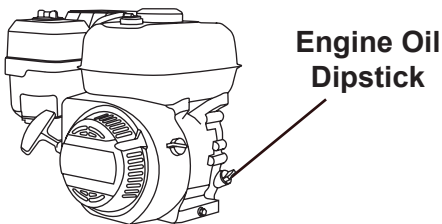

**Fig. 19**

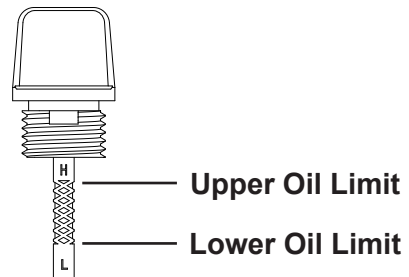

**Fig. 20**

## Checking Fuel



**WARNING:**

**REFUELING**

Gasoline is highly flammable and gasoline vapors are extremely explosive. Fire and explosions can cause severe burns and/or death. Keep gasoline away from flames, sparks, and other ignition sources. Refuel outdoors in a well-ventilated area with the engine stopped and cool. Wipe up any spilled gasoline and allow engine to dry before starting. Keep a fire extinguisher handy while refueling. Do not operate engine with leaks in the fuel system. Do not store gasoline near other flammable materials. Store fuel in a clean, OSHA-approved container in a secured location away from the work area.



**NOTICE**

**OLD GASOLINE**

Old gasoline can create deposits that clog fuel systems causing hard starting and poor performance. Damage caused by old fuel is not covered by warranty. To minimize deposits, avoid old fuel related performance issues, and prevent costly repair work, do not use gasoline that is older than 30 days.



**NOTICE**

**ALCOHOL BLENDS**

Using gasoline with an alcohol blend greater than 10% (E10) will damage the engine. Damage caused by using an alcohol blend of 15% (E15), 85% (E85), or any other alcohol blend higher than 10% (E10) is not covered under warranty. To avoid engine damage caused by an alcohol blend that is too high, use gasoline with 10% (E10) alcohol or lower.



**NOTICE**

**GASOLINE ADDITIVES**

The use of fuel system cleaning additives can damage the engine and fuel systems. Damage caused by the use of fuel system cleaning additives is not covered by warranty. To avoid engine and fuel system damage, do not use any fuel system cleaning additives.



**CAUTION:**

**FUEL TANK PRESSURE**

Gasoline vapor can build up inside the fuel tank creating pressure. This pressure may increase when the engine is hot from running. Opening the fuel tank under pressure can cause rapid escape of flammable vapors and possible fuel spills that may ignite from contact with hot engine surfaces resulting in burn hazard. To avoid these hazards, always allow the engine to cool for at least 2 minutes before removing fuel cap and loosen the fuel cap slowly to relieve any pressure in the tank.



## **NOTICE**

### **GASOLINE STORAGE**

It is important to prevent gum deposits from forming in essential fuel system parts, such as the carburetor, fuel filter, fuel hose or tank during storage. Alcohol-blended fuels (also called gasohol, ethanol, or methanol) attract moisture, which leads to separation and formation of acids during storage. Acidic fuel and gum deposits can damage the engine's fuel system while in storage. Damage caused by the use of old, stale, or contaminated fuel are not covered under warranty.



## **NOTICE**

### **DO NOT OVERFILL FUEL TANK**

Overfilling the fuel tank can result in carbon canister damage (if equipped), poor engine performance, and void the warranty. To avoid these hazards, do not fill the fuel tank above the maximum level.

1. Check the fuel with the engine off and the trailer on level pavement.
2. Remove the fuel tank cap, check level then fill fuel tank if needed. For the fuel cap location see the FEATURES AND CONTROLS section of the Engine Owner's Manual.
3. Do not use gasoline that is older than 30 days. Use only fresh unleaded gasoline with a minimum octane rating of 87 and no more than 10% ethyl alcohol. Do not mix oil with the gasoline.
4. Do not fill the fuel tank above the maximum fuel level to allow room for fuel expansion.
5. Replace fuel tank cap. Never run engine without the fuel cap in place and tightened.

**NOTE:** Using a fuel stabilizer (sold separately) when storing gasoline can help prevent problems related to storing ethanol alcohol blended gasoline. Always follow the instructions provided by the fuel stabilizer manufacturer to mix and use correctly.

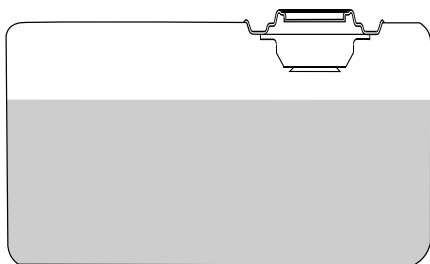

**Maximum Fuel Level**

# STARTING THE ENGINE



**! WARNING:**

## OPERATING CHECKLIST

Attempting to start the engine incorrectly can result in engine and/or pump damage, and may cause serious injury or death. To avoid these hazards, be sure to read, understand, and follow the steps outlined in the OPERATING CHECKLIST section of the owner's manual before starting the engine, and follow all the guidelines for proper use of the SIMPSON Water Trailer.



**NOTICE**

## PUMP PRIMING

This pump will not prime when dry. Running the pump dry without priming can damage the pump assembly and seals. Damage caused by running dry is not covered by warranty. To avoid damaging the seals and pump assembly, do not run the pump when it is dry without priming.

## Starting the Engine

1. Complete the steps in the OPERATING CHECKLIST section of this manual before starting the engine. Failure to do so could cause damage to the engine. If needed, refer to your Engine Owner's Manual for specific starting instructions. Lastly, make sure the pump is primed and the trailer is ready for the desired operation.
2. Turn the engine switch to the ON position.



3. Slide the fuel valve to the ON position.



4. Slide the throttle to the RUN position.



5. Slide the choke to CHOKE for starting a COLD engine. Slide to RUN for a warm engine



**NOTE:** The starting position of the choke will vary depending on the engine temperature. If starting a cold engine, move the choke lever towards the CHOKE position. If starting a warm engine, move the choke lever towards the RUN position.

6. Pull the recoil slowly until resistance is felt, then pull rapidly to start the engine. Do not allow the starter grip to snap back. Return it gently by hand.



**NOTE:** If the engine should not start after two pulls, squeeze the gun trigger to release stored pressure. Then, try again to start the engine.



**WARNING:**

**RAPID RETRACTION**

Rapid retraction (also known as kickback) of the engine recoil starter cord will pull your hand and arm towards the engine faster than you can let go of the handle resulting in sprains, broken bones, lacerations, and/or traumatic amputations. Kickback is caused by damage to the engine crankshaft key, compression release failure, and/or improper starting techniques. To avoid kickback follow the appropriate maintenance schedule, starting instructions and have repair work done by an authorized service center.

7. Once the engine starts, slowly move the choke lever to RUN as the engine runs. If the engine falters, move the choke toward CHOKE until the engine has warmed up.



**NOTICE**

**PUMP DAMAGE**

Never allow the tank water level to fall below a level of one inch above the outlet pipe of the tank. If the tank fully drains, pump damage may occur from lack of water and you will only be able to refill the tank from a pressurized water source. When you approach this level, TURN OFF THE ENGINE.



# SHUTTING DOWN THE ENGINE

1. Slide the throttle to the SLOW position. Allow the speed of the engine to decrease.

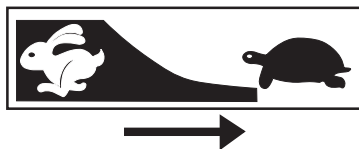

2. Turn the engine switch to OFF.



3. Slide the fuel switch to OFF.



## TROUBLESHOOTING

ISSUE	POSSIBLE CAUSE	SOLUTION
Engine will not start.  Refer to the Engine Owner's Manual for more engine troubleshooting information.	The fuel tank is empty.	Add fresh fuel.
	Engine switch is in the OFF position.	Turn the engine switch to the ON position.
	Engine fuel valve is turned OFF.	Turn fuel valve ON.
	Engine choke is in the wrong position.	Refer to the STARTING THE ENGINE section of this manual for the correct choke position.
	The spark plug lead is not attached to the plug.	Connect spark plug lead.
	Engine oil is low. If the engine is equipped with a Low Oil Sensor, the engine will not start.	Check engine oil level. Fill per the Engine Owner's Manual.

# MAINTENANCE

For safety reasons, the manufacturer recommends all service and repairs be performed by an authorized service center. All warranty replacement and repairs must be performed by an authorized distribution or service center. To find an authorized service center near you, to make a warranty claim or for authorized warranty repair, call 1-833-362-7368 or contact through email at [cservice@fna-group.com](mailto:cservice@fna-group.com)

It is the responsibility of the owner and / or operator to have all scheduled maintenance completed before transporting or operating the SIMPSON Water Trailer. Be sure to follow the inspection and maintenance recommendations as listed in all of the manuals that came with this unit.

## Pump Maintenance

Before each use, check the pump for loose or damaged parts and any other condition that may affect proper operation. Be sure all safety guards are in place and in proper working order. Inspect all air vents and cooling slots to ensure they are clean and unobstructed. For safety reasons, the manufacturer recommends all service and repairs be performed by an authorized service center. To find an authorized service center near you, to make a warranty claim or for authorized warranty repair, call 1-833-362-7368 or contact through email [cservice@fna-group.com](mailto:cservice@fna-group.com)



**CAUTION:**

**MAINTENANCE**

Improper engine and pump maintenance as well as failing to correct problems before operation could void the warranty and may result in property damage and injury. To prevent these hazards, follow the maintenance procedures listed in this manual and any other manual that came with the product.



**WARNING:**

**RISK OF BURNING**

When performing maintenance, you may be exposed to hot surfaces, water pressure, or moving parts that can cause serious injury or death. Always disconnect spark plug wire and let the engine cool before performing any maintenance or repair. The engine contains flammable fuel. Do not smoke or work near open flames while performing maintenance.



**WARNING:**

**MODIFICATION INJURY**

Never modify the product or any part of it. Damage or personal injury could result.

## Exterior Pump Cleaning

Always clean the pump with the engine off and cool. To clean the pump, first use an air compressor set at 25 PSI to clear dirt and debris from the pump surfaces, vents and cooling slots. Next, wipe the exterior with a damp cloth.



**NOTICE**

**CLEANING**

Water can damage the engine components if allowed to enter through cooling slots or other holes. Damage caused by water intrusion is not covered under warranty. To avoid engine water damage, do not use a pressure washer, garden hose, or any other sources of running water to clean the engine and never submerge the pump/engine in any liquids.

## Interior Pump Cleaning



### **NOTICE**

#### **CHEMICAL CLEANERS**

Using chemical cleaners and/or corrosive liquids can damage the pump seals and internal components. Damage caused by chemical cleaners and corrosive liquids is not covered under warranty. To avoid damaging pump seals and components, do not use chemical cleaners or corrosive liquids to clean the components inside the pump housing.



### **WARNING:**

#### **MOVING PARTS**

This product has many parts that move at high speeds. Moving parts can cause crushing injuries, broken bones, severe lacerations, and/or traumatic amputations. To prevent injury, never place fingers, hands, feet, or other body parts near running engine. Never operate product with covers, shrouds, or other guards removed. Do not wear loose-fitting clothing, dangling drawstrings, or any other hanging items that could become entangled in moving parts while operating. Tie up long hair and remove jewelry before operating.

Keeping the pump clean will allow it to perform its best and prolong the life of the pump. Never pump water from a standing source without using a filter / screen. Do not store the pump without draining the pump housing. Do not allow dirt or debris to dry inside the pump housing. You can clean the interior of the pump by following the steps below:

1. Disconnect the spark plug lead from the engine. Place it to the side of the plug.
2. Drain the system as outlined in DRAINING THE SYSTEM FOR STORAGE section of this manual.
3. Using a screw or nut driver, loosen the worm screw clamps (Fig. 21). Carefully remove them from the flanges then slide them to the right.

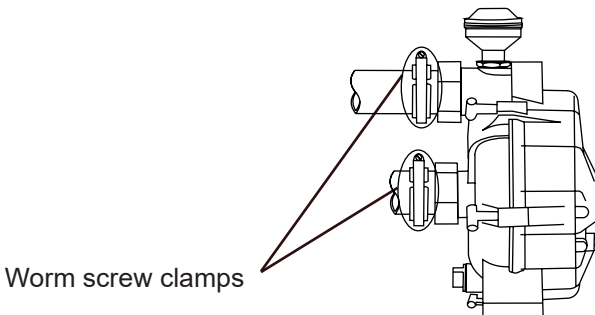

**Fig. 21**

4. Using an open end wrench, loosen and remove the six nuts (four under the engine, two under the pump) and their washers that hold the unit to the frame (Fig. 22).

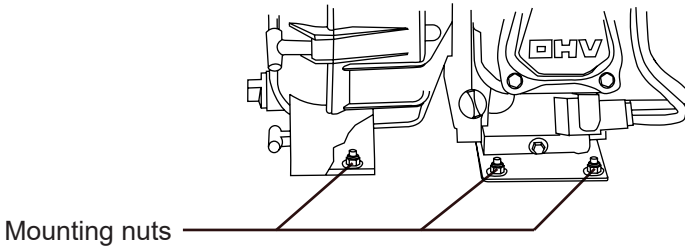

**Fig. 22**

5. With the assistance of another person, lift the engine/pump assembly off of the bolts and turn it 180 degrees so the pump faces the driver's side of the trailer.

6. Remove the outer pump housing cover bolts (Fig. 23 - A)

7. Remove the outer pump housing cover (Fig. 23 - B) and its rubber seal (Fig. 23 - C).

8. Remove the check valve (Fig. 23 - D).

9. Remove the impeller/volute (Fig. 23 - E).

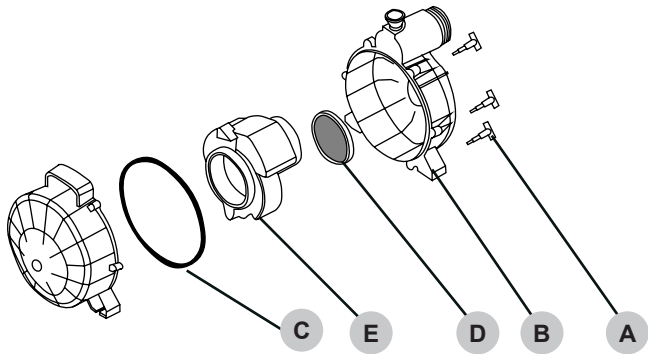

**Fig. 23**

10. Remove all dirt and debris from the components then rinse them clean with fresh water. Do not use chemicals to clean the internal pump components as they may damage the seals.

11. Reassemble the pump components making sure the rubber seals are in their proper locations and do not get pinched or damaged during reassembly.

12. With the assistance of another person, lift the engine/pump assembly and rotate it back into position on the bolts.

13. Place the nuts and washers back onto the mounting bolts. Tighten with an open end wrench.

14. Place the worm screw clamps back onto the fittings. Tighten.

15. Place the spark plug lead back onto the spark plug.

## **Engine Maintenance**

Before each use, check the engine for loose or damaged parts, signs of oil or fuel leaks and/or any other condition that may affect proper operation. Always keep all safety guards in place and in proper working order. Repair or replace all damaged or defective parts immediately.

For safety reasons, the manufacturer recommends all engine service and repairs (including emission control devices and systems) to be performed by an authorized service center. All warranty replacements or repairs must be performed by an authorized distribution or service center. To find an authorized service center near you, obtain information about how to make a warranty claim or to make arrangements for authorized warranty repairs, please call 1-833-362-7368 or contact through email at [service@fna-group.com](mailto:service@fna-group.com)

For all other information on engine maintenance, refer to your Engine Owner's Manual.

## **Plumbing Maintenance**

The plumbing of the SIMPSON Water Trailer was designed to give years of worry-free life. However, it is important to monitor all connections for leaks. If the trailer is not to be used for an extended period of time, make sure to drain the trailer of water as talked about in the DRAINING THE SYSTEM FOR STORAGE section of the manual. It is of utmost importance to winterize the system if freezing weather is expected. Routinely rotate all valves to make sure they move freely without binding.

Inspect the nozzles on the spray bar for debris that may cause the spray pattern to be inconsistent. Remove large pieces of debris with needle-nosed pliers then sweep the orifice of the nozzle with a small bottle brush to remove any remaining particles.

## **Trailer Maintenance**

For trailer maintenance, safety and towing information, please see the SIMPSON Trailer Operations Manual, part number 7114734.

# ENGINE LONG-TERM STORAGE

## Storing for Two Months or Less *(or when freezing temperatures are expected)*

1. Make sure the engine is off and cool.
2. Fill the fuel tank per the OPERATING CHECKLIST section of this manual, and then add a fuel stabilizer per the manufacturer's recommendations.

**NOTE:** Using a fuel stabilizer (sold separately) when storing gasoline may help prevent the problems related to alcohol blended fuels in outdoor power equipment engines. Always follow the instructions provided by the fuel stabilizer manufacturer to mix and use correctly.

3. Make sure the water in the tank is a minimum of 1" above the outlet pipe (Fig. 9).
4. Move the FLOW valves to the BYPASS position (Figs. 1 and 4).
5. Move the TANK valve to OPEN to begin purging air and priming the pump (Figs. 1-2).
6. Ensure the pump is primed and air is fully purged from the pump. If you start to remove the primer cover and water begins to flow out, it is primed. If not, remove the cover and fill the pump with water (Fig. 8). Thread the cover back onto the funnel; tighten.
7. Start the engine per the STARTING THE ENGINE section of this manual.

Allow the engine to run for a minimum of two minutes to allow the fuel stabilizer to circulate throughout the fuel system.

8. Shut off the engine by using the SHUTTING DOWN instructions.
9. Drain the tank, pump and plumbing system per the DRAINING THE SYSTEM FOR STORAGE section of this manual.

## Storing for More Than Two Months

1. Make sure the engine is off and cool.
2. Drain the tank, pump and plumbing system per the DRAINING THE SYSTEM FOR STORAGE section of this manual.

3. Using an appropriate container, completely drain the fuel system by removing the drain screw on the bottom of the carburetor (Fig. 24). Open the fuel tank cap to make sure all of the gasoline has drained from the system. Thread in the drain screw once the fuel is removed.

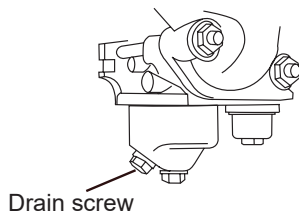

**Fig. 24**

4. Change the engine oil; see the Engine Owner's Manual for reference.
5. Remove any dirt or debris from the area around the spark plug. Using a spark plug wrench, remove the spark plug.
6. Pour 0.5 ounces (15mL) of new engine oil into the engine combustion chamber.
7. Slowly crank the engine by pulling on the recoil two times to distribute the oil and lubricate the cylinder.
8. Hand thread the spark plug then tighten with the spark plug wrench. Torque to meet the requirements set forth in the Engine Owner's Manual.

# DRAINING THE SYSTEM FOR STORAGE (WINTERIZE)

When you will not be using the trailer for an extended period of time or there is a chance of freezing weather, you should drain the system.

## DRAINING THE SYSTEM

1. Ensure the trailer is as level as possible.
2. Using a screw or nut driver, loosen the worm screw clamp (Fig. 25 - A). Carefully remove it and the manifold plug from the tee flange.
3. Remove the drain plug on the bottom of the pump (Fig. 25 - B).
4. Move the TANK valve to the OPEN position to allow the tank to empty (Fig. 1-2).
4. Remove the primer cover from the pump allowing air into the pump (Fig. 25 - C).
5. As the system drains, operate the FLOW valves (Figs. 1 and 4) to allow any trapped water to drain.
6. Once the water has stopped flowing, replace the caps and manifold plug; tighten.
7. Move the TANK valve to the CLOSED position (Fig. 1-2).

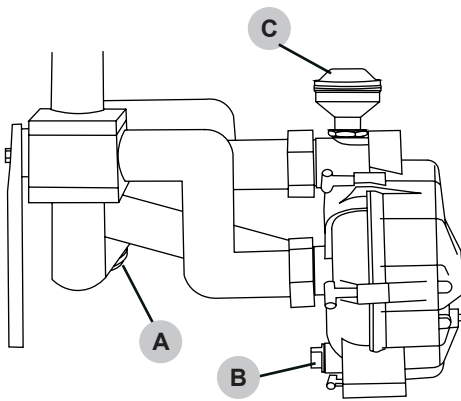

Fig. 25

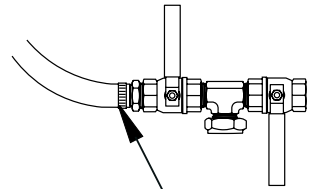

Fig. 26

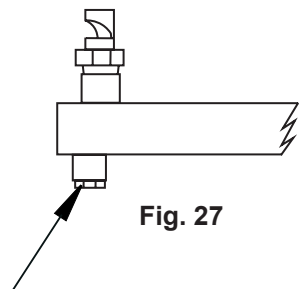

Fig. 27

8. Using a screw or nut driver, loosen the hose clamp (Fig. 26). Carefully remove the hose and lower it, allowing residual water to drain.
9. Remove the drain plugs from the bottom of the spray bar near each nozzle (Fig. 27).
10. Allow any trapped water to drain from the hose and the spray bar.
11. Thread in the drain plugs; tighten.
12. Align the hose assembly back with the manifold, position the clamp and tighten.

# LIMITED WARRANTY

## Industrial / Rental Products

### WARRANTY COVERAGE TERMS:

The manufacturer of this product agrees to repair or replace designated parts that prove defective within the warranty period listed below at the manufacturers sole discretion. Specific limitations/extensions and exclusions apply.

This warranty covers defects in material and workmanship and not parts failure due to normal wear, depreciation, abuse, accidental damage, negligence, improper use, maintenance, water quality and storage. To make a claim under the terms of the warranty, all parts said to be defective must be retained and available for return upon request to a designated Warranty Service Center for warranty inspection. The judgments and decisions of the manufacturer concerning warranty claims are final.

These warranties pass through to the end user and are non-transferable. As a factory authorized and trained Warranty Service Center, the factory will honor the terms of all component warranties and satisfy claims of the appropriate warranty provisions.

Normal wear items included, but are not limited to, items such as valve and seals, which are not covered by this warranty.

This warranty replaces all warranties, express or implied, including without limitation any warranties of merchantability or fitness for a particular purpose and all such warranties are hereby disclaimed and excluded by the manufacturer. The manufacturer's warranty obligation is limited to repair and replacement of defective products as provided herein and the manufacturer shall not be liable for any further loss, damages, or expenses - including damages from shipping, accident, abuse, acts of God, misuse, or neglect. Neither is damage from repairs using parts not purchased from the manufacturer or alterations performed by non-factory authorized personnel. Failure to install and operate equipment according to the guidelines put forth in the instruction manual shall void warranty.

### THIS WARRANTY DOES NOT COVER:

Damage resulting from shipping (claims must be filed with freighter), accident, abuse, acts of God, misuse or neglect. This warranty also does not cover damage from repairs or alterations performed by non-factory authorized personnel or failure to install and operate equipment according to the guidelines put forth in the instruction manual. The manufacturer will not be liable to any persons for consequential damage, for personal injury or for commercial loss.

### RESPONSIBILITY OF ORIGINAL PURCHASER (INITIAL USER):

To process a warranty claim on your SIMPSON® water trailer, report the concern to 1-833-362-7368 or [cservice@fna-group.com](mailto:cservice@fna-group.com) for authorization and direction to the nearest authorized service center in your area.

Retain original cash register receipt as proof of purchase for warranty work.

Use reasonable care in the operation and maintenance of the product as described in the Owner's Manual.

### WHAT THIS WARRANTY DOES NOT COVER:

- Freight damage
- Damage due to chemical deterioration, scale build up, rust, corrosion or thermal expansion
- Freeze damage
- Damage caused by parts or accessories not obtained from an authorized dealer or not approved by the manufacturer
- Normal wear of moving parts or components affected by moving parts

### WARRANTY COVERAGE PERIODS:

#### ENGINE AND EMISSIONS CONTROL SYSTEM

- Three (3) years from date of purchase (see engine manual for details).

#### PUMP (DEFECTS IN MATERIAL AND WORKMANSHIP)

- Five (5) years from date of purchase

#### FRAME (DEFECTS IN MATERIAL AND WORKMANSHIP)

- One (1) year from date of purchase

#### ACCESSORIES (DEFECTS IN MATERIAL AND WORKMANSHIP)

- Ninety (90) days from date of purchase



# NOTES

---

---

**THIS PAGE WAS INTENTIONALLY LEFT BLANK**

**THIS PAGE WAS INTENTIONALLY LEFT BLANK**

**THIS PAGE WAS INTENTIONALLY LEFT BLANK**



**READ THIS MANUAL CAREFULLY BEFORE OPERATION**

Failure to follow the instructions and safety precautions in this manual can result in property damage, serious injury and/or death.

**SAVE THIS MANUAL FOR FUTURE REFERENCE**

Copyright © 2025 FNA-Group, Inc. All rights reserved.