



TRAILER MOUNTED PRESSURE WASHER

95004

This powerful SIMPSON® cold water mobile pressure washing system will handle all your commercial jobs. It's perfectly suited for contract cleaners, mobile detailers, municipalities, and resorts. The trailer is dot certified as an over-the-road pressure washer system. Job-Site set-up is a snap. Pull up to the work area, connect the spray gun, start the engine and begin cleaning. Equipped with a (50-State compliant) VANGUARD® engine with an electric start and reliable CAT PUMPS® industrial triplex pump.

COLD WATER MOBILE TRAILER

FRAME

Welded steel frame construction with powder-coated finish for durability and corrosion resistance

VANGUARD® 479cc ENGINE

Equipped with low oil shutdown feature with e-start

PREMIUM 6-PLY TIRES

For increased mobility across various terrains

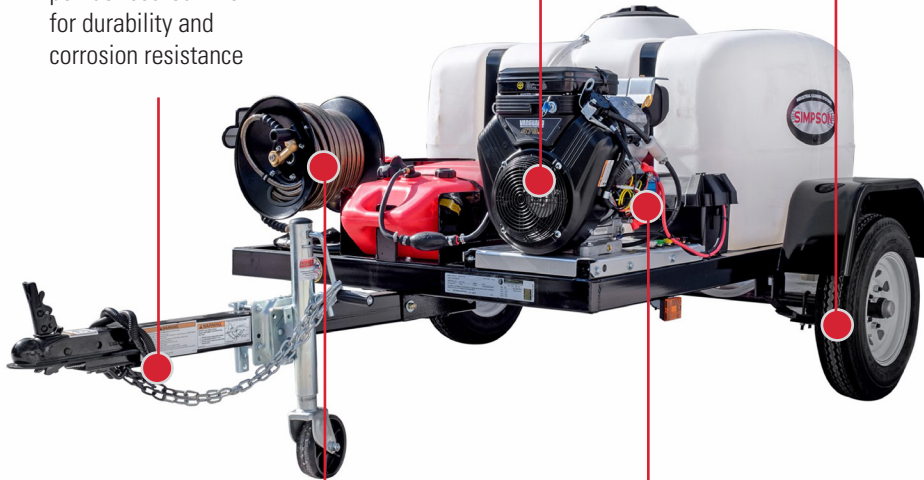

STEEL-BRAIDED MONSTER HOSE

Kink and abrasion resistant hose with quick connect fittings and polyurethane outer jacket

CAT PUMPS® INDUSTRIAL TRIPLEX

Integrated unloader for easy pump maintenance

PART# 95004 ***49-State DOES NOT SHIP to CA***

PRESSURE RATING: 4200 PSI

FLOW RATING: 4.0 GPM

ENGINE: VANGUARD® 479cc w/ E-Start

PUMP: CAT PUMPS® Industrial Triplex

TRAILER SIZE: 9' Overall (4'x5'6" Platform)

TRAILER FRAME: Rectangular thick wall steel tubing

AXLE RATING: 2000 lbs

TIRE: 12" 6-Ply

LIGHTING: LED

TRAILER HITCH BALL SIZE: 2" Ball

WATER TANK SIZE: 150 gal

HIGH PRESSURE HOSE: 3/8" x 100' Monster Hose w/ QC

HIGH PRESSURE HOSE REEL: 100'

SUPPLY HOSE: Optional 3/4" x 75'

SUPPLY REEL: Optional

DIMENSIONS/WEIGHT: 80" x 72" x 52" | 1,000 lbs.

LIMITED PRODUCT WARRANTIES

**3 YEAR
ENGINE
WARRANTY**

**5 YEAR
PUMP
WARRANTY**

**1 YEAR
FRAME
WARRANTY**



For more information, please contact a SIMPSON Sales Representative at 847-348-1500 or email SALES@FNA-GROUP.COM

WWW.SIMPSONCLEANING.COM